



flowboost[®]

H.V Pump Manual

OPERATION AND MAINTENANCE MANUAL

First Publication Date: 01/09/2020

Revision:

Revision Date:

General

Information

These instructions are to assist in the installation of the flowboost H.V Pump please follow them carefully.

If, having read this Operation & Maintenance Manual, there is any doubt about any aspect of the installation please don't hesitate to contact our technical team.

Definitions of Safety Warnings and Precautions



WARNING!

Indicates a potentially hazardous situation which, if not avoided, can result in serious injury or death.



CAUTION!

Indicates a potentially hazardous situation which, if not avoided. Can result in minor to moderate injury, or serious damage to the product.

Safety

Information

It is essential that correct and safe working practices are adhered to at all times when installing, operating and/or maintaining any piece of equipment. Always consult safety data sheets, operating and maintenance manuals, Health & Safety legislation and recommendations and specific requirements of any equipment manufacturer, site controller, building manager or any other persons or organisation relating to the procurement, installation, operation and/or maintenance of any piece of equipment associated or in conjunction with any product provided by **flowtech** Water Solutions.

This document is intended for ALL installers, operators, users and persons carrying out maintenance of this equipment and must be kept with the equipment, for the life of the equipment and made available to all persons at all times. Prior to carrying out any work associated with the set it is essential that the following sheets are read, fully understood and adhered to at all times.

Equipment must only be installed, operated, used, and/or maintained by a competent person. A competent person is someone who is technically competent and familiar with all safety practices and all of the hazards involved.

Any damage caused to any equipment by misapplication, mishandling or misuse could lead to risk of Electrocutation, Burns, Fire, Flooding, death or injury to people and/or damage to property dependent upon the circumstances involved. **flowtech** Water Solutions accepts no responsibility or liability for any damage, losses, injury, fatalities or consequences of any kind due to misapplication, mishandling or misuse of any equipment, or as a result of failure to comply with this manual.

Failure to install, operate, use or maintain the equipment in accordance with the information contained within this document could cause damage to the equipment and any other equipment subsequently connected to it, invalidating any warranties provided by **flowtech** Water Solutions to the buyer.

Safety Warnings &

Precautions

These instructions should be read and clearly understood before working on the system. Please read this manual carefully and all of the warning signs attached before installing or operating the equipment keep this manual handy for your reference. This equipment should be installed, adjusted and serviced by trained and qualified personnel. Failure to observe this precaution could result in bodily injury.



WARNING! - Install an emergency stop key separately from the isolator. Rotating shafts can be hazardous.



WARNING! - This equipment has a high leakage current and must be permanently fixed to earth.



WARNING! - Do not attach or remove wiring or connectors when the power is applied. Do not check signals during operation. When the power is turned on and the running command is on, the motor will start rotating. The stop key is only effective when the function is set. If there is a power failure and an operation instruction is given the unit may start automatically when the power is reinstated.



WARNING! - Make sure that the input voltage is correct. Be sure to install the unit in a room that is not exposed to direct sunlight and is well ventilated.

Avoid environments which have a high ambient temperature, high humidity or excessive condensation. Avoid dust. Corrosive gas, explosive gas, inflammable gas, grinding-fluid mist and salt damage, etc.



WARNING! - Do not connect the power source to any terminals except power connectors.



WARNING! - Motor control equipment and electronic controllers are connected to hazardous line voltages. When servicing drives and electronic controllers, you may be exposed to components at or above the line potential. Extreme care should be taken to protect against shock. Dangerous voltage may exist after the power light is off.

Wait more than 5 minutes after turning off the power supply before performing maintenance or inspection. Hazard of electric shock. Disconnect incoming power before working on this unit.



WARNING! - The inverter should be protected separately against ground fault.

Observe the regional regulations for electrical installation!



CAUTION! - It is strongly recommended that all electrical equipment conforms to National Electrical Codes and local regulations. Only qualified personnel should perform installation, alignment and maintenance. The manufacturer reserves the right to alter the technical data in order to make improvements or update information.



CAUTION! - Failure to observe these rules will render the guarantee invalid. The same applies to repair jobs and/or replacement. Your legal rights are not affected.



CAUTION! - The manufacturer declines all responsibility in the event of damage or injury caused as a result of tampering with the equipment.



CAUTION! - Do not switch on/off power supply to run/stop the motor/system! Start the unit only by using run button or external run command.

Customer / Contractor **RESPONSIBILITIES**

It is the responsibility of the customer and/or the contractor:

- To ensure that anyone working on the equipment is wearing all necessary protective gear and/or clothing.
- Is aware of appropriate health & safety warnings.
- Has read the information in this section of the manual.

Protection of the environment

Comply with the current regulations on sorted waste disposal.

Leaking of fluid

If the unit contains lubricating fluid, take appropriate measures to prevent the dispersion of leaks into the environment.

Sites exposed to ionizing radiations

If the unit has been exposed to ionizing radiations, implement the necessary safety measures for the protection of people. If the unit needs to be despatched, inform the carrier and the recipient accordingly, so that appropriate safety measures can be put in place.

Handling and Storage

The unit and its components may be heavy: risk of crushing.

Always wear personal protective equipment.

Check the gross weight marked on the packaging.

Handle the unit in compliance with the current regulations on “manual load handling“, to avoid undesirable ergonomic conditions causing risks of back-spine injury.

Take appropriate measures during transport, installation and storage to prevent contamination from external substances.

Depending on the model, the unit and its components in:

A cardboard box, or

A cardboard box with wooden base.

The type 2 packaging is intended for transport with a forklift truck; the lifting points are indicated in the figure.

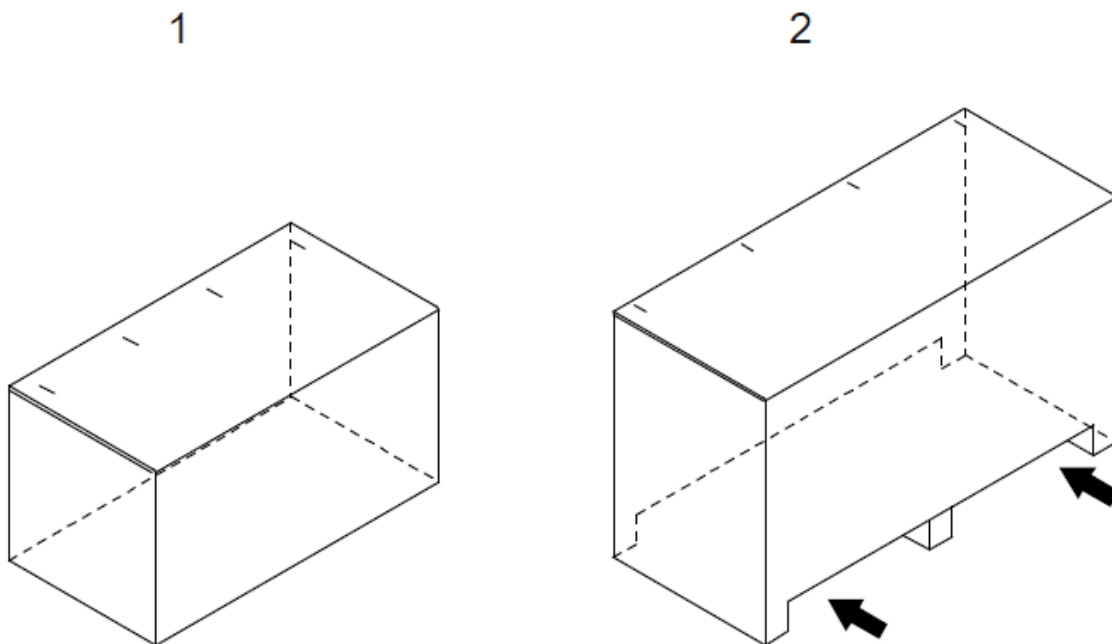

Unit inspection upon delivery

Inspect the package.

Check that quantity, descriptions and product codes match the order.

Check the packaging for any damage or missing components.

In case of immediately detectable damage or missing parts:

Accept the goods with reserve, indicating any findings on the transport document, or

Reject the goods, indicating the reason on the transport document.

Unpacking and inspection of the unit

Always wear personal protective equipment.

Remove packing materials from the product.

Release the unit by removing the screws and / or cutting the straps, if fitted.

Check the unit for integrity and to make sure that there are no missing components .

In case of damage or missing components, promptly contact Flowtech.

Use cranes, ropes, lifting straps, hooks and clasps that comply with current regulations and that are suitable for the specific use.

Make sure that the harnessing does not hit and / or damage the unit.

Lift and handle the unit slowly to avoid stability issues .

During handling, make sure to avoid injury to people and animals, and / or damage to property.

Do not use eye-bolts screwed on the motor for handling the unit.

The pump is shipped with two shims to block the shaft and the impeller stack; always handle the pump with the shims installed to prevent damage.

The unit must be harnessed and lifted as shown in the figures.

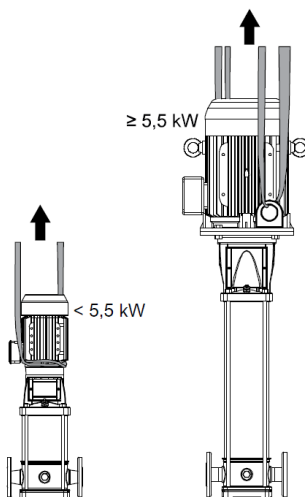

The eye-bolts must only be used to move the unit upright from its horizontal position on the ground, and only for as long as strictly necessary . See the figures below.

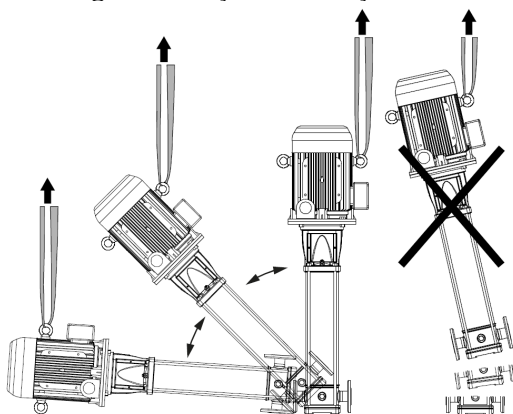

Storage of the packed unit

The unit must be stored:

- In a covered and dry place
- Away from heat sources
- Protected from dirt
- Protected from vibrations
- At an ambient temperature between -5°C and +40°C and relative humidity between 5% and 95%.
- Do not place heavy loads on top of the unit.
- Protect the unit from collisions.

Long-term storage of the unit

1. Empty the unit by unscrewing the drain plug; this operation is essential in environments with cold temperatures. Otherwise, any residual liquid in the unit could have an adverse effect on its condition and performance.



2. Follow the same instructions for the storage of the packed unit.

Technical Description

Multi-stage vertical centrifugal pump unit, non-self-priming.

The product may be supplied as a pump unit (pump and motor), or as pump only.

Intended use

- Pressure boosting and water supply systems
- Washing and cleaning sector, including washing of vehicles
- Circulation of hot and cold liquids, for example water or water & glycol, for heating, cooling and air conditioning systems
- Water treatment applications
- Transfer of moderately aggressive liquids
- Irrigation
- Fire fighting systems.

Pumped liquids

- Clean
- Chemically and mechanically non aggressive
- Hot water
- Cold water.

Improper use

The unit was designed and built for the use described in section Intended use. Any other uses are prohibited, as they could compromise the safety of the user and the efficiency of the unit itself.

It is prohibited to use this unit to pump flammable and/or explosive liquids.

It is prohibited to start the unit in environments with potentially explosive atmospheres or with combustible dusts.

Examples of improper use

Pumping liquids not compatible with the construction materials of the unit
Pumping hazardous, toxic, explosive, flammable or corrosive liquids
Pumping drinking liquids other than water, for example wine or milk
Pumping liquids containing abrasive, solid, or fibrous substances
Using the unit for flow rates exceeding the flow rate indicated in the data plate.
Examples of improper installation

Use in water distribution networks for human consumption

If the unit is intended for water supply to people and/or animals:
It is prohibited to pump drinking water after use with other fluids.
Take appropriate measures during transport, installation and storage to prevent contamination from external substances.
Remove the unit from its packaging just before installation to prevent contamination from external substances.
After installation, run the unit for a few minutes with several users open in order to wash the inside of the system.

Explosive and corrosive atmospheres

Areas where the air temperature is very high and/or there is poor ventilation
Outdoor without protection from weather conditions.
Use in water distribution networks for human consumption
If the unit is intended for water supply to people and/or animals: It is prohibited to pump drinking water after use with other fluids.
Take appropriate measures during transport, installation and storage to prevent contamination from external substances.
Remove the unit from its packaging just before installation to prevent contamination from external substances.
After installation, run the unit for a few minutes with several users open in order to wash the inside of the system.

Installation

All the hydraulic and electrical connections must be completed by a technician possessing the technical-professional requirements outlined in the current regulations.
It is prohibited to start the unit in environments with potentially explosive atmospheres or with combustible dusts.
Always wear personal protective equipment.
Always use suitable working tools.
When selecting the place of installation and connecting the unit to the hydraulic and electric power supplies, strictly comply with current regulations.
When connecting the unit to a public or private aqueduct, or to a well for the supply of water for human and/or animal consumption.

Mechanical installation

Install the unit on a concrete or metal foundation base sufficiently strong to ensure permanent and rigid support.

Installation area

- Place the unit in a raised position in relation to the floor.
- Make sure that any leaks will not cause flooding to the installation area or submerge the unit.

Air clearance between a wall and the motor fan grille

- To ensure suitable ventilation: 100 mm(4 in)
- To permit inspection and removal of the motor: 300 mm(12 in)
- If the space available is any less, refer to the technical catalogue.

Permitted positions

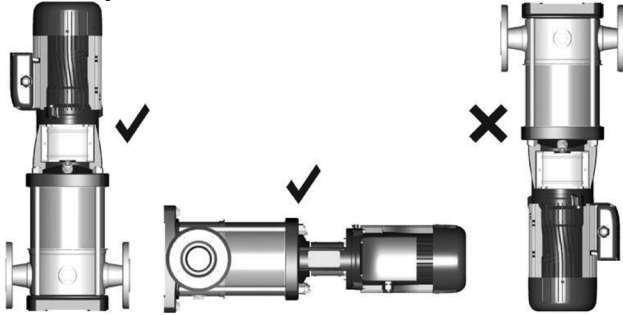

Installation on concrete foundation

- The concrete must have a compression resistance of C12/15 and meet the requirements of exposure class XC1 according to EN 206-1
- Sizes must be appropriate for the sizes of the unit support plate.
- The foundation weight must be 1.5 times the unit weight(5 times the weight of the unit if a quieter operation is required)
- The surface should be as flat and level as possible.

Fastening of the unit

- If present, remove the plugs covering the suction and discharge ports.
- Place the unit on the foundation.
- Using a spirit level, make sure that the unit is level.
- Align the suction and discharge ports to their piping.
- Secure the unit with 4 bolts with resistance class 8.8 or higher; see the table.

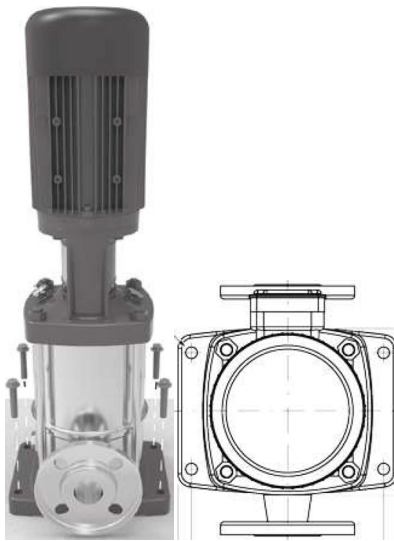

Model	L1,mm(in)	L2,mm(in)	L3,mm(in)	L4,mm(in)	O,mm(in)	Bolt size
1, 3, 5	100(3,94)	180(7,09)	150(5,90)	210(8,27)	13(0,51)	M12
10,15, 22	130(5,12)	215(8,46)	185(7,28)	245(9,65)		
33	170(6,69)	240(9,45)	220(8,66)	290(11,41)	15(0,59)	M14

Reducing vibrations

The engine and the flow of liquids in the piping can generate vibrations, which may be amplified from the possible incorrect installation of the unit and the piping.

Hydraulic connection

All the hydraulic and electrical connections must be completed by a technician possessing the technical-professional requirements outlined in the current regulations.

Piping must be sized to ensure safety at the maximum operating pressure.

Install appropriate seals between the unit couplings and the piping.

Guidelines for the hydraulic system

Refer to the representative hydraulic diagrams; see the figures below.

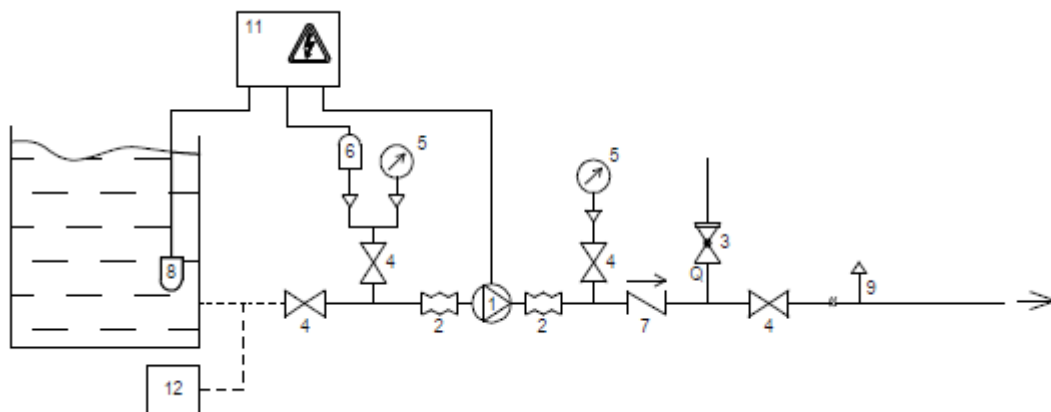

Figure 1: Positive suction head installation

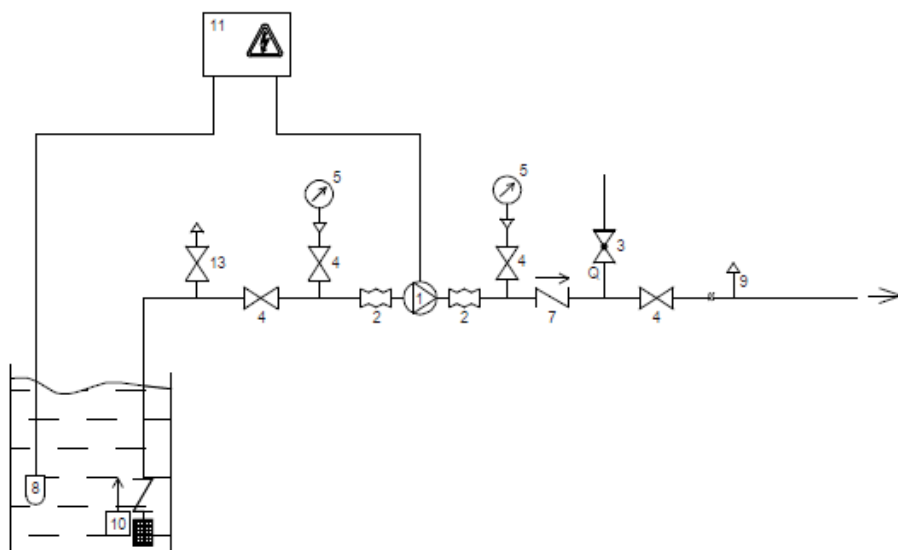
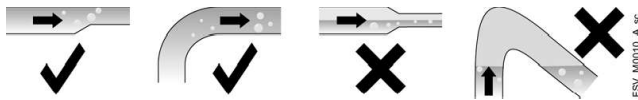

Figure 2: Suction lift installation

Position number	Description	Position number	Description
1	Pump unit	8	Electrode probes or float
2	Anti-vibration joint	9	Automatic relief valve
3	Overpressure safety on-off valve	10	Foot check valve with filter
4	On-off valve	11	Electric panel
5	Pressure gauge	12	Pressurised circuit
6	Minimum pressure switch	13	Filling on-off valve
7	Check valve		

- Do not install the unit at the lowest point of the system, to avoid the accumulation of sediments.
- Install an automatic relief valve at the highest point of the system to eliminate air bubbles .
- Remove any welding residues, deposits and impurities in the pipes that could damage the unit; install a filter if necessary.

- Support the pipes independently to prevent them from weighing on the unit.
- To reduce the transmission of vibrations between the unit and the system and vice versa, Install anti-vibration joints on the suction and discharge sides of the unit
Dampers between the unit and the surface on which it is installed.
- In order to reduce flow resistance, the pipe on the suction side must be:
As short and as straight as possible
For the section connected to the unit, straight and without bottlenecks, covering a length equal to at least six times the diameter of the suction port
Wider than the suction port; if necessary, install an eccentric reducer that is horizontal on top
Without bends; if this cannot be avoided, bends of a radius as wide as possible
Without traps and ‘goosenecks’
With on-off valves with a low specific flow resistance.



- Install a check valve on the discharge side to prevent the liquid from flowing back into the pump unit when this is at standstill.
- Install a pressure gauge (or a vacuum pressure gauge, in case of suction lift installation) on the suction side, and a pressure gauge on the discharge side, for checking the actual operating pressure of the pump unit.
- To exclude the unit from the system for the purpose of maintenance, install:
An on-off valve on the suction side
An on-off valve on the discharge side, downstream the check valve and pressure gauge, also useful for regulating the flow rate.
- On the suction side, install a device to prevent the absence of liquid (float or probes), or a minimum pressure device.
- Sufficiently submerge the end of the suction pipe in the liquid, in order to prevent any air from penetrating through the suction vortex when the level is at the minimum
- In case of suction lift installation, the suction pipe must have an increasing slope towards the unit exceeding 2%; to avoid air pockets; also install :
A foot check valve that guarantees full opening (full section)
A filling on-off valve to facilitate the removal of the air and priming .

Forces and torques applicable to the flanges

The table shows the maximum allowable forces and torques exerted by the piping on the flanges of the unit.

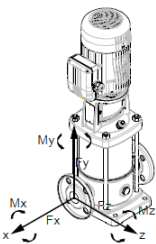

Model DN, mm (in) Forces, N (lbf) Torques, Nm (lbf-in)

Model	DN, mm (in)	F _x	F _y	F _z	M _x	M _y	M _z
1,3SV	25(0,98)	200(45)	180(41)	230(52)	240(2124)	160(1416)	190(1682)
5SV	32(1,26)	260(59)	240(54)	300(68)	310(2744)	210(1859)	250(2213)
10SV	40(1,57)	330(74)	300(68)	370(83)	390(3452)	270(2390)	310(2744)
15,22SV	50(1,97)	450(101)	400(90)	490(110)	420(3718)	300(2656)	340(3010)
33SV	65(2,56)	1800(405)	1700(382)	2000(450)	1500(13 276)	1050(9294)	1200(10 621)
46SV	80(3,15)	2250(506)	2050(461)	2500(562)	1600(14 161)	1150(10 179)	1300(11 506)

Electrical connection

All the hydraulic and electrical connections must be completed by a technician possessing the technical-professional requirements outlined in the current regulations.

Before starting work, check that the unit is unplugged and that the pump unit, the control panel and the auxiliary control circuit cannot restart, even unintentionally.

Before starting work, make sure that the general electric requirements and/or those of the firefighting systems (hydrants or sprinklers) comply with local regulations.

Ground

Always connect the external protection conductor (ground) to the ground terminal before attempting to make any other electrical connections.

Connect all the electrical accessories of the pump unit and motor to the ground.

Check that the external protection conductor (ground) is longer than the phase conductors; In case of accidental disconnection of the unit from the phase conductors, the protection conductor must be the last one to detach itself from the terminal.

Install suitable systems for protection against indirect contact, in order to prevent lethal electric shocks.

Guidelines for electrical connection

1. Check that the electrical leads are protected against:
 - High temperature
 - Vibrations
 - Collisions.
2. Check that the power supply line is provided with:
 - A short circuit protection device of appropriate size
 - A mains disconnection device with contact opening distance ensuring complete disconnection for over voltage III category conditions.

Guidelines for the electrical control panel

The electric panel must match the ratings on the unit data plate. Improper combinations could damage the motor.

Install appropriate devices for protecting the motor from overloads and short circuits:

Motor	Safety Features
Single-phase	Automatic reset thermal-ampere protection, in-built (motor protector)
	From short circuit, by the installer: aM fuses (motor start-up), or thermal magnetic switch with C curve and $I_{cn} \geq 4.5 \text{ kA}$, or other similar device.
	Thermal, by the installer: trip class 10 A overload thermal relay+ aM fuses (motor start-up), or start class 10 A motor protection thermal magnetic Three-phase switch
Three-phase	From short circuit, by the installer: aM fuses (motor start-up), or thermal magnetic switch with C curve and $I_{cn} \geq 4.5 \text{ kA}$, or other similar device.

Fit a system for protection against dry running to which to connect a pressure switch, or a float, probes or other suitable devices.

On the suction side install:

- A pressure switch, in the case of connection to the mains water supply
- A float switch or probes, in the case of liquid drawn from a tank or basin.

If required, install phase failure sensitive thermal relays.

Guidelines for the motor

If using a motor other than the standard motor, check that a thermal protection device has been installed. The unit, equipped with a single-phase motor with automatic reset thermal overload protection, could restart inadvertently after it has cooled down: risk of physical injury.

The use of units with single-phase motors with automatic reset thermal protection for extinguishing fires and in pulverised water firefighting systems is forbidden.

Only use dynamically balanced motors with half-sized key at the shaft end (IEC 60034-14), and with normal vibration rate (N).

The mains voltage and frequency must match the specifications on the data plate.

Positioning of the motor terminal box

The position of the terminal box may be changed to facilitate the electric connections :

Remove the 4 bolts that secure the motor to the pump.

Rotate the motor in the desired position without removing the couplings. 3 . Reposition and tighten the bolts at the torque indicated in the table .

Motor size	Bolt size	Torque, Nm (lbf-in)
71, 80	M6	6 (53)
90, 100, 112	M8	15 (133)
132	M12	50 (443)
160, 180, 200, 225, 250	M16	75 (664)

Electrical connection of the motor

Open the terminal box cover.

Connect the power supply conductors; see the figure below or the wiring diagram shown inside the cover.

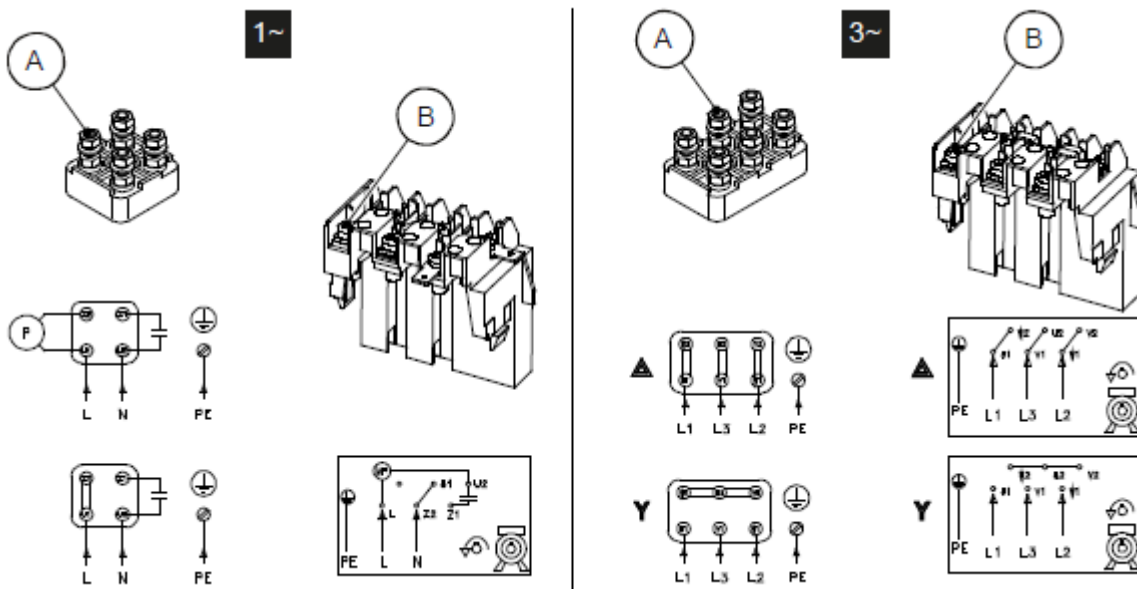

Position Number	Bolt Size	Torque, Nm (lbf-in)
A	M4	1,2 (11)
	M5	2,5 (22)
	M6	4,0 (35)
	M8	8,0 (71)
	M10	15,0 (133)
B	M4	1,2 (11)

3. Connect the protection conductor (ground), making sure that it is longer than the phase conductors.
4. Connect the phase leads.
5. Close the terminal box cover and tighten all the screws and cable glands.

Motor without automatic reset thermal overload protection

1. If the motor is used with full load, then set the value to the nominal current value on the data plate of the pump unit.
2. If the motor is used with partial load, then set the value of the operating current measured with a current pincer.
3. For three-phase motors with star-delta starting system, set the thermal relay downstream of the switching circuit at 58% of the rated or operating current.

Operation with frequency converter

The three-phase motors can be connected to a frequency converter for speed control. The converter exposes the insulation of the motor to a greater load, determined by the length of the connecting cable: observe the requirements of the Manufacturer of the frequency converter. For applications requiring silent operation, install an outlet filter between the motor and the converter; a sinusoidal filter can reduce the noise even further. The bearings of the motors, from size 315 S/M and up, are exposed to the risk of harmful currents: use electrically insulated bearings.

The conditions of installation must guarantee protection against voltage peaks between the terminals and/or dV/dt in the table:

Motor size	Voltage peak, V	dV/dt, V/μs
up to 90R (500 V)	<650	<2200
from 90R to 180R	<1400	<4600
over 180R	<1600	<5200

Otherwise, use a motor with reinforced insulation 1 and a sinusoidal filter.

Use and operation

Check that the protection devices of the coupling are installed, when applicable: risk of physical injury. Make sure that the drained liquid cannot cause damage or injuries. Check that the unit is properly connected to the mains power supply. The unit, equipped with a single-phase motor with automatic reset thermal overload protection, could restart inadvertently after it has cooled down: risk of physical injury. Be aware of the extreme heat generated by the unit. It is prohibited to put combustible materials near the unit. Check that the shaft can turn smoothly. It is prohibited to operate the unit when dry, not primed and below the minimum rated flow rate. It is prohibited to operate the unit with the on-off valves on the suction and discharge sides closed. It is prohibited to use the unit in the case of cavitation. The unit must be filled and vented properly before it can be started. The maximum pressure delivered by the unit at the discharge side, determined by the pressure available on the suction side, must not exceed the maximum pressure (PN).

Filling - Priming

In the case of liquids that are excessively hot or cold, pay attention to the risk of injury.

Positive suction head installation Models 1, 3 and 5

1. Close the on-off valves on the suction (A) and discharge (B) sides; see the figure below.
2. Loosen the drain plug (C).
3. Loosen the filling plug (D).
4. Slowly open the on-off valve (A) until the liquid regularly comes out from the hole; if necessary, loosen the plug further (D).
5. Tighten the plug (C).
6. Tighten the plug (D).
7. Open both the on-off valves slowly and fully.

Models 10, 15, 22, 33,

1. Close the on-off valves on the suction (A) and discharge (B) sides; see the figure below.
2. Loosen the filling plug (D).
3. Slowly open the on-off valve (A) until the liquid regularly comes out from the hole; if necessary, loosen the plug further (D).
4. Tighten the plug (D).
5. Open both the on-off valves slowly and fully.

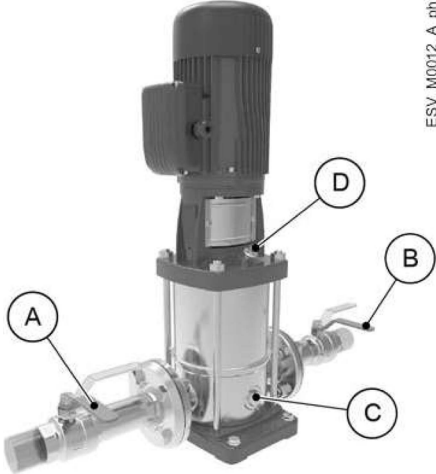

Suction lift installation Models 1, 3 and 5

1. Open the on-off valves on the suction (A) and discharge (B) sides; see the figure below.
2. Loosen the drain plug (C).
3. Remove the filling plug (D).
4. Fill the pump unit until the liquid comes out of the hole.
5. Tighten the plug (C).
6. Close the plug (D).
7. Slowly fully open the on-off valve on the discharge side.

Models 10, 15, 22, 33

1. Open the on-off valves on the suction (A) and discharge (B) sides; see the figure below.
2. Remove the filling plug (D).
3. Fill the pump unit until the liquid comes out of the hole.
4. Close the plug (D).
5. Slowly fully open the on-off valve on the discharge side.

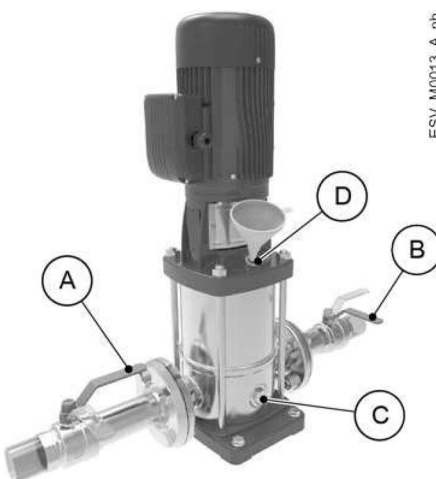

Rotation sense check (three-phase motors)

Before starting the unit:

Check that the shaft can turn smoothly.

1. Locate the arrow on the adapter, the coupling or the cover, to determine the correct direction of rotation of the motor.
2. Start the unit.
3. Check the direction of rotation through the coupling protection, or through the motor cover.
4. Stop the unit



Wrong rotation direction

1. Disconnect the power supply.
2. Invert two of the three wires of the power supply cord.

Start-up

It is prohibited to operate the unit with the discharge side on-off valve closed or at zero flow rate : this can cause the liquid to overheat and damage the unit.

If there is a risk of the unit running at a flow rate below the minimum expected , install a bypass circuit.

Check that the shaft can turn smoothly.

1. Check that all the operations indicated in Filling - Priming and in Rotation sense check have been completed correctly.
2. Shut off the discharge on-off valve almost completely .
3. Fully open the suction on-off valve.
4. Start the unit.
5. Gradually open the discharge on-off valve until half open.
6. Wait a few minutes and then fully open the discharge on-off valve.

After the start-up procedure, with the pump unit in operation , check that :

- No liquid is leaking from the unit or pipes
- The maximum pressure of the unit at the discharge, determined by the available suction pressure, must not exceed the maximum pressure (PN)
- The current absorbed is within the rated limits (calibrate the thermal overload protection of the motor)
- There is no unwanted noise or vibrations
- At zero flow rate , the pressure at the discharge corresponds to the expected nominal pressure
- No vortices can occur at the end of the suction pipe, at the point of the foot check valve (suction lift installation).

If the units does not deliver the required pressure, repeat the operations in Filling - Priming.

After start up, run the unit for a few minutes with several users open in order to wash the inside of the system .

Settling of the mechanical seal

The pumped liquid lubricates the seal faces of the mechanical seal; under normal conditions, a small amount of liquid may leak out. When the unit is run for the first time, or immediately after the seal is replaced, more liquid may temporarily leak out. To help the seal settle and to reduce leaking:

1. Close and open the on-off valve on the discharge side two or three times with the unit running.
2. Stop and start the unit two or three times.

Stopping

1. Shut the on-off valve located on the discharge line.
2. Stop the pump unit and check that the motor slows down gradually.
3. Gradually re-open the on/off valve and check that the motor remains still.

Maintenance

Before starting, make sure that the instructions shown in Introduction and Safety have been fully read and understood.

Maintenance must be done by a technician possessing the technical-professional requirements outlined in the current regulations.

Always wear personal protective equipment.

Always use suitable working tools.

In the case of liquids that are excessively hot or cold, pay attention to the risk of injury .

Before starting work, check that the unit is unplugged and that the pump unit, the control panel and the auxiliary control circuit cannot restart , even unintentionally .

If the unit is connected to the frequency converter, disconnect the mains power supply and wait at least 10 minutes for the residual current to dissipate .

Maintenance every 4000 hours of operation, or every year

When the first of the two limits is reached :

1. Measure the pressure at zero flow rate and compare it with the pressure measured during initial start-up if the pressure has decreased by more than 15%, check the condition of impeller, pump body and wear rings.
2. Check the unit for unwanted noise and vibrations.
3. Check that there is no liquid leaking from the unit or pipes.
4. Check that all the screws and bolts of the unit and pipes are properly fastened.
5. Check that the insulation resistance of the motor is greater than 500 MΩ, applying a test voltage of 500 Vdc for 1 minute .
6. Check the terminal board of the motor for any signs of overheating and arc flashes.
7. Check the condition of the motor's cooling fan and clean it.
8. Check the integrity of the power cable .

Long periods of inactivity

1. Close the on-off valve on the suction side.
2. Completely empty the unit.
3. Protect the unit against freezing.
4. Before restarting the unit, check that the shaft is rotating freely, without mechanical impediments.
5. Tightening torques of the threaded connections

Tightening torques of the threaded connections

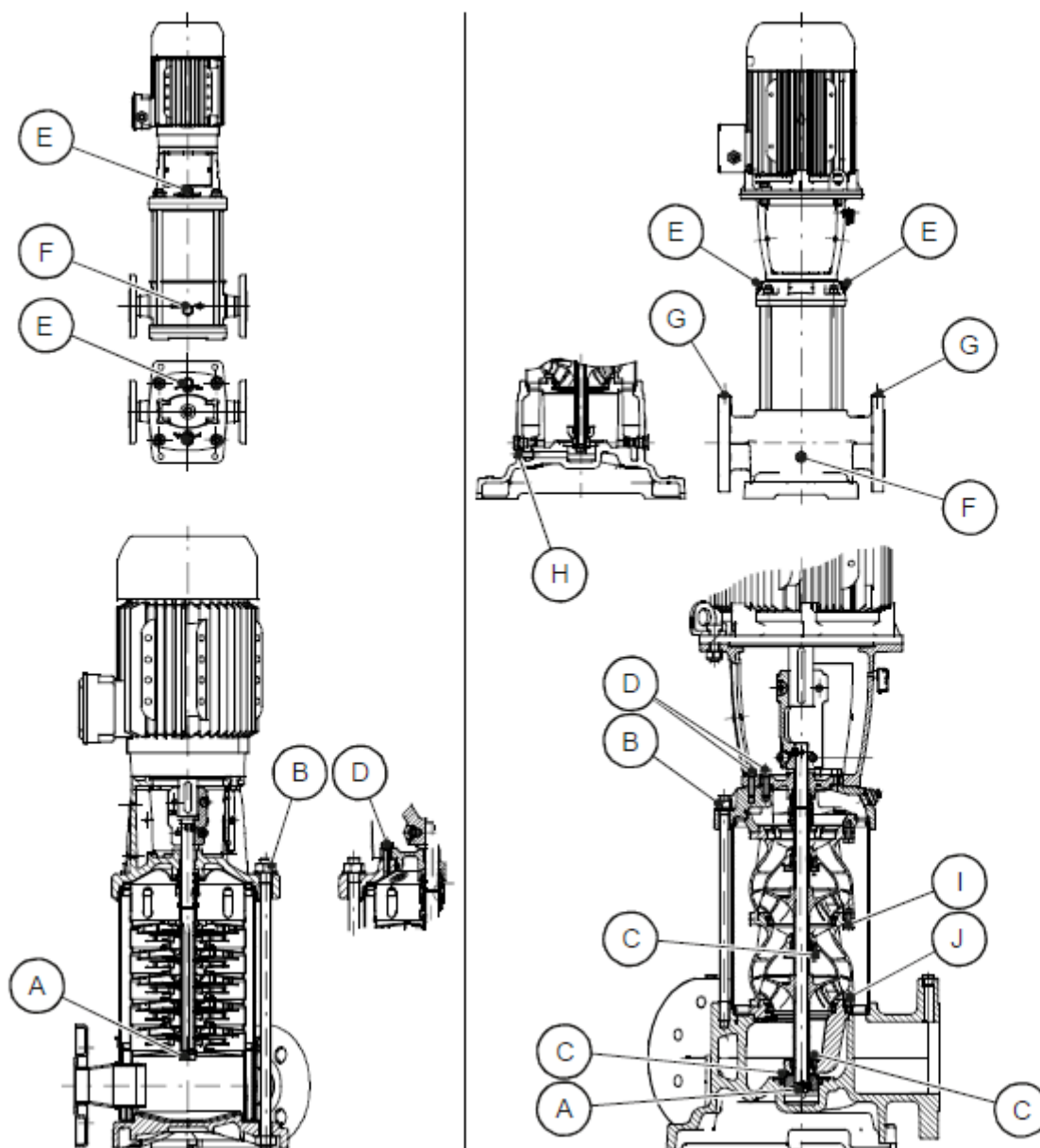

Table 1: Tightening torques of the threaded fittings, Nm (lbf in)

Model	A	B	C	D	E, F	G	H	I	J
1, 3, 5	M8	M12	-	-	G 3/8"	-	-	-	-
	20 (177)	25 (220)	-	-	25 (220)	-	-	-	-
10, 15, 22	M10	M14	-	M8	G 3/8"	-	-	-	-
	35 (310)	30 (265)	-	20 (177)	25 (220)	-	-	-	-
33, 46,	M12	M16	M6	M10	G 1/2"	R 3/8"	M16	-	-
	60 (530)	60 (530)	8(71)	35 (310)	40 (354)	40 (354)	40(354)	-	-

Spare parts ordering

Identify the spare parts with the product codes.

Troubleshooting

Maintenance must be done by a technician possessing the technical professional requirements outlined in the current regulations.

If a fault cannot be corrected or is not mentioned contact Flowtech.

The unit does not start

Cause	Remedy
Power supply cut off	Restore the power supply
The thermal overload protection of the motor has been triggered	Reset the thermal overload protection on the control panel or the unit
The device that detects the absence of liquid or minimum pressure has been triggered	Top up the liquid or restore minimum pressure
The capacitor, if present, is faulty	Replace the capacitor
Control panel faulty	Check and repair or replace the control panel
Motor (coil) faulty	Check and repair or replace the motor

The differential protection device (RCD) is activated

Cause	Remedy
Motor leaking	Check and repair or replace the motor
Unsuitable type of differential	Check the type of differential

The thermal overload protection triggers or the fuses trip

The motor thermal overload protection triggers or the fuses trip when the unit starts.

Cause	Remedy
It is calibrated at a value too low in relation to the rated current of the motor	Recalibrate
Missing power supply phase	Check the power supply and restore the phase
Loose and/or faulty connections of the thermal overload protection	Tighten or replace the clamps and terminals
Loose and/or incorrect and /or faulty (star-delta) connections in the terminal board of the motor	Tighten or replace the clamps and terminals
Motor (coil) faulty	Check and repair or replace the motor
Pump unit mechanically seized	Check and repair the pump unit
Check valve faulty	Replace the check valve
Foot check valve faulty	Replace the foot check valve

The thermal overload protection triggers

The motor thermal overload protection triggers occasionally, or after the unit has been running for a few minutes.

Cause	Remedy
It is calibrated at a value too low in relation to the rated current of the motor	Recalibrate
Input voltage outside the rated limits	Make sure the voltage values are correct
Unbalanced Input voltage	Make sure the voltage of the three phases is balanced
Incorrect working curve (flow rate greater than the maximum permitted flow rate)	Reduce the required flow rate

Liquid too dense, presence of solid or fibrous substances (unit overloaded)	Reduce the density of the liquid Reduce the solid substances Increase the size of the motor
Room temperature too high, exposure to sunlight	Lower the temperature at the point of the thermal overload protection Protect against direct sunlight
Unit Faulty	Send the unit back for testing

The motor becomes excessively hot

Cause	Remedy
Room temperature outside the rated limits	Lower the room temperature
Cooling fan of the motor clogged or damaged	Clean or replace the cooling fan
The unit starts up too frequently	See the section: The unit produces excessive noise and/or vibrations
The frequency converter, if present, has not been calibrated properly	See the frequency converter manual

The unit runs but there is little or no flow rate

Cause	Remedy
Motor turns in the wrong direction	Check the direction of rotation and change it if necessary
Incorrect priming (there are air bubbles in the suction pipe or in the unit)	Repeat the priming procedure
Cavitation	Increase the NPSH ² available in the system
Check valve locked in closed or partially closed position	Replace the check valve
Foot check valve locked in closed or partially closed position	Replace the foot check valve
Discharge pipe throttled	Remove the throttling
Piping and/or unit clogged	Remove the clogging

When switched off, the unit turns in the opposite direction

Cause	Remedy
Check valve faulty	Replace the check valve
Foot check valve faulty	Replace the foot check valve

The unit produces excessive noise and/or vibrations

Cause	Remedy
Cavitation	Increase the NPSH ³ available in the system
Unsuitable anchoring to the ground	Check the anchoring to the ground
Resonance	Check the installation
Anti-vibration joints not installed	Install anti-vibration joints on the suction and discharge sides of the unit
Foreign bodies in the unit	Remove the foreign bodies
Motor bearings worn or faulty	Replace the motor bearings
The unit does not turn freely due to a mechanical fault	Send the unit to an authorised workshop for testing

The unit starts up too frequently (automatic start/stop)

Cause	Remedy
Incorrect priming (there are air bubbles in the suction pipe or in the unit)	Repeat the priming procedure
Check valve locked in closed or partially closed position	Replace the check valve
Foot check valve locked in closed or partially closed position	Replace the foot check valve
Starter (pressure switch, sensor, etc.) set incorrectly, or faulty	Adjust or replace the starter
Expansion vessel <ul style="list-style-type: none"> • No pre-charge, or • Undersized, or • Not installed 	<ul style="list-style-type: none"> • Pre-charge the expansion vessel, or • Replace the expansion vessel with another suitable one, or • Install an expansion vessel

The unit never stops (automatic start/stop)

Cause	Remedy
The required flow rate is greater than the one expected	Reduce the required flow rate
Discharge pipe leaking	Eliminate the leaks
Motor turns in the wrong direction	Check the direction of rotation and change it if necessary
Pipes, on-off valves or filter clogged with impurities	Remove the impurities
Starter (pressure switch, sensor, etc.) Set in correctly, or faulty	Adjust or replace the starter
The unit runs but there is little or no flow rate	See the section : The thermal overload protection triggers

The unit is leaking

Cause	Remedy
Worn mechanical seal	Replace the mechanical seal, or Fit a mechanical seal with harder seal faces
Mechanical seal damaged due to thermal shock (presence of air bubbles in the unit)	Replace the mechanical seal
Defective mechanical seal	Replace the mechanical seal
Mechanical seal damaged due to temperature of the liquid outside the rated limits	Replace the mechanical seal with another of a suitable make
Mechanical seal damaged due to chemical incompatibility with the liquid	Replace the mechanical seal with one of a make chemically with the liquid compatible with the pumped liquid

The frequency converter is in error mode or turned off

The frequency converter (if present) is in error mode or turned off

Cause	Remedy
See the frequency converter manual	See the frequency converter manual

Technical Information

Operating environment
Non-aggressive and non-explosive atmosphere .

Temperature

From 0 to 40°C (32+104°F), unless otherwise indicated on the data plate of the electric motor.

Relative air humidity

< 50% at 40°C (104°F).

If the humidity exceeds the stated limits, contact Flowtech.

Elevation

< 1000 m (3280 ft) above sea level.

If the unit is exposed to temperatures or installed at an altitude greater than those stated, reduce the power output of the motor according to the coefficients reported in the table. Otherwise, replace the motor with a more powerful one.

Altitude m (ft)	Power reduction coefficient
1000+1500 (3300+4900)	0.97
1500+ 2000 (4900+6600)	0.95

Temperature of pumped liquid

The table shows the permitted liquid temperatures according to the mechanical seal.

Seal material	Minimum and maximum temperature, °C (°F)
EPDM	-30+120 (-22+248)
FKM (FPM)	-10+120 (14+248)
PTFE	0+120 (32+248)

Maximum number of starts per hour

Motor power, kW (hp)	Starts h
0.25 - 3 (0.33 - 4)	60
4-7.50(5.4-10)	40
11-15(14.8-20.1)	30
18.5- 22 (24.8-29.5)	24
30- 37 (40.2 - 49.6)	16
45- 75 (60.3-100)	8
90-160(120-215)	4

Protection class

IP 55.

Electrical specifications

Permitted tolerances for the supply voltage

Frequency Hz	Phase -	No. of conductors+ earth	UN, V± %
50	1	2 + 1	220+240 ± 6
	3	3 + 1	230/400 ± 10, 400/690 ± 10

Sound pressure

Measured in free field at a distance of one metre from the unit, with standard motor operating without load.
50 Hz motors

Sound pressure level LwA: 95 dB± 2

Disposal

The unit must be disposed of through approved companies specialised in the identification of different types of materials (steel, copper, plastic, etc.).

It is prohibited to dispose of lubricating fluids and other hazardous substances in the environment.

Information to users (WEEE other than WEEE from private households), pursuant to art. 14 of the Directive 2012/19/EU of the European Parliament and of the Council of 4 July 2012 on waste electrical and electronic equipment (WEEE).



The crossed bin symbol on the appliance or on its packaging indicates that the product at the end of its useful life must be collected separately and not disposed of together with other mixed urban waste. The separate collection of this equipment at the end of its life is organized and managed by the producer. The user who wants to get rid of this equipment can then contact the producer and follow the system that it has adopted to allow the separate collection of equipment at the end of life, or select a supply chain independently authorized to manage. Appropriate separate collection for the subsequent start-up of the disused equipment for recycling, treatment and environmentally compatible disposal helps to avoid possible negative effects on the environment and on health and favours the re-use and/ or recycling of the materials it is composed of the equipment.

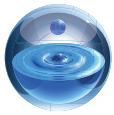

flowtech[®]
WATER SOLUTIONS

flowzone[®]

MEMBERS AREA

This section of the **flowtech**[®] website holds information exclusively for members. Members will need to log in to gain access to these pages.

Our member's will be granted exclusive access to our technical resource library. Within this resource is a wide range of product information including data sheets, technical drawings, O&M Manuals and training videos



flowcare[®]

AFTER SALES SERVICE

At **flowtech**[®] we operate a network of Service Engineers located throughout the UK who are supported by our offices located in and Greater Manchester. The distribution of engineers means that in the majority of cases we are less than 4 hours away from attending a customer call out.

We place great emphasis on providing technical back up to support our Service Engineers in resolving some difficult operational and technical issues. We pride ourselves on completing a project on time, within budget and never leaving a problem unresolved, or a customer waiting. This quality of service has made us the first choice for our customers.

FOR FURTHER INFORMATION OR ASSISTANCE

contact us

Flowtech Water Solutions are experts in water services and water booster sets. We have continuously supplied a wide range of standard and custom products since being founded in 1996.

MANUFACTURE & SUPPLY

TELEPHONE : 0333 200 1756

EMAIL: info@flowtech.org.uk

SERVICE & MAINTENANCE

TELEPHONE : 0333 200 1813

EMAIL: service@flowtech.org.uk

WEBSITE: www.flowtech.org.uk

ADDRESS : Unit 1 Lock Flight Buildings, Wheatlea Industrial Estate,
Wigan, Greater Manchester WN3 6XP United Kingdom



Membership No. 700106

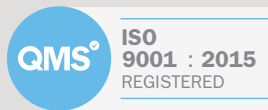

Certificate No. 185352020