



flowcon[®]

VSD - E Inverter

OPERATION AND MAINTENANCE MANUAL

First Publication Date: 01/09/2020

Revision:

Revision Date:

OPERATION & MAINTENANCE CONTENTS

GENERAL INFORMATION	3
SAFETY INFORMATION	4
SAFETY WARNINGS & PRECAUTIONS	5
CUSTOMER / CONTRACTOR RESPONSIBILITIES	6
Warranty	7
Description	7
Dimensions	8
Technical Data	8
Functions	9
Protections	9
Installation Hydraulic Connection	10
Electrical Connection	12
Line Connection	13
Pump Connection	13
Auxiliary Connector Connection	14
Start Up	16
Programming	16
User Parameters	17
Installer Parameters	18
Alarms	21
Troubleshooting	22
Maintenance	23

General Information

These instructions are to assist in the installation of the flowcon VSD - E Inverter please follow them carefully.

If, having read this Operation & Maintenance Manual, there is any doubt about any aspect of the installation please don't hesitate to contact our technical team.

Definitions of Safety Warnings and Precautions



WARNING!

Indicates a potentially hazardous situation which, if not avoided, can result in serious injury or death.



CAUTION!

Indicates a potentially hazardous situation which, if not avoided. Can result in minor to moderate injury, or serious damage to the product.

Safety

Information

It is essential that correct and safe working practices are adhered to at all times when installing, operating and/or maintaining any piece of equipment. Always consult safety data sheets, operating and maintenance manuals, Health & Safety legislation and recommendations and specific requirements of any equipment manufacturer, site controller, building manager or any other persons or organisation relating to the procurement, installation, operation and/or maintenance of any piece of equipment associated or in conjunction with any product provided by **flowtech** Water Solutions.

This document is intended for ALL installers, operators, users and persons carrying out maintenance of this equipment and must be kept with the equipment, for the life of the equipment and made available to all persons at all times. Prior to carrying out any work associated with the set it is essential that the following sheets are read, fully understood and adhered to at all times.

Equipment must only be installed, operated, used, and/or maintained by a competent person. A competent person is someone who is technically competent and familiar with all safety practices and all of the hazards involved.

Any damage caused to any equipment by misapplication, mishandling or misuse could lead to risk of Electrocutation, Burns, Fire, Flooding, death or injury to people and/or damage to property dependent upon the circumstances involved. **flowtech** Water Solutions accepts no responsibility or liability for any damage, losses, injury, fatalities or consequences of any kind due to misapplication, mishandling or misuse of any equipment, or as a result of failure to comply with this manual.

Failure to install, operate, use or maintain the equipment in accordance with the information contained within this document could cause damage to the equipment and any other equipment subsequently connected to it, invalidating any warranties provided by **flowtech** Water Solutions to the buyer.

Safety Warnings &

Precautions

These instructions should be read and clearly understood before working on the system. Please read this manual carefully and all of the warning signs attached before installing or operating the equipment keep this manual handy for your reference. This equipment should be installed, adjusted and serviced by trained and qualified personnel. Failure to observe this precaution could result in bodily injury.



WARNING! - Install an emergency stop key separately from the isolator. Rotating shafts can be hazardous.



WARNING! - This equipment has a high leakage current and must be permanently fixed to earth.



WARNING! - Do not attach or remove wiring or connectors when the power is applied. Do not check signals during operation. When the power is turned on and the running command is on, the motor will start rotating. The stop key is only effective when the function is set. If there is a power failure and an operation instruction is given the unit may start automatically when the power is reinstated.



WARNING! - Make sure that the input voltage is correct. Be sure to install the unit in a room that is not exposed to direct sunlight and is well ventilated.

Avoid environments which have a high ambient temperature, high humidity or excessive condensation. Avoid dust. Corrosive gas, explosive gas, inflammable gas, grinding-fluid mist and salt damage, etc.



WARNING! - Do not connect the power source to any terminals except power connectors.



WARNING! - Motor control equipment and electronic controllers are connected to hazardous line voltages. When servicing drives and electronic controllers, you may be exposed to components at or above the line potential. Extreme care should be taken to protect against shock. Dangerous voltage may exist after the power light is off.

Wait more than 5 minutes after turning off the power supply before performing maintenance or inspection. Hazard of electric shock. Disconnect incoming power before working on this unit.



WARNING! - The inverter should be protected separately against ground fault.

Observe the regional regulations for electrical installation!



CAUTION! - It is strongly recommended that all electrical equipment conforms to National Electrical Codes and local regulations. Only qualified personnel should perform installation, alignment and maintenance. The manufacturer reserves the right to alter the technical data in order to make improvements or update information.



CAUTION! - Failure to observe these rules will render the guarantee invalid. The same applies to repair jobs and/or replacement. Your legal rights are not affected.



CAUTION! - The manufacturer declines all responsibility in the event of damage or injury caused as a result of tampering with the equipment.



CAUTION! - Do not switch on/off power supply to run/stop the motor/system! Start the unit only by using run button or external run command.

Customer / Contractor **RESPONSIBILITIES**

It is the responsibility of the customer and/or the contractor:

- To ensure that anyone working on the equipment is wearing all necessary protective gear and/or clothing.
- Is aware of appropriate health & safety warnings.
- Has read the information in this section of the manual.

The manufacturer is not liable for malfunctioning if the product has not correctly been installed, damaged, modified, and/or run outside the recommended work range or not in accordance with other indications given in this manual.

The Manufacturer declines all responsibility for possible errors in this instructions manual, if due to misprint or error in copying.

The Manufacturer reserves the right to make any modifications to products that it may consider necessary or useful, without affecting the essential characteristics.

The responsibility of the manufacturer is limited to the product and excludes costs or greater damage caused by incorrect installation.

Types

Type (single-phase)	Frequency converter max current output A	Standard power V230 motor kW
Flowcon E 9,2MM	9,2	0,37 - 1,5

Type (three-phase)	Frequency converter max current output A	Standard power V230 motor kW
Flowcon E 9,2MT	9,2	0,37 - 2,2

Operating conditions

(Standard execution)

The electrical panel functions correctly under the following power and installation characteristics:

- Power fluctuation: +/-10% max
- Frequency fluctuations: +/- 4 % max
- Ambient temperature: -10 °C a + 40 °C
- Relative humidity: from 20% to 90% without condensation
- Vibration: max 5,9 m/s² (0,6 g) to 10-55 Hz
- Altitude: no higher than 1000 m, inside a closed environment.
- Max liquid temperature:
 - 50 °C Flowcon E 5MM, 9,2MM, 5MT, 9,2MT
 - 40 °C Flowcon E 7,5MT
- Minimum delivery: 3 l/min



The current distributed by the frequency converter must be equal to or lower than the maximum current absorbed by the motor to control.

Construction

(Standard execution)

The system is composed of:

- Frequency converter.
- Pressure transducer.
- Pipe housings.
- Fixing screws.
- Terminal board.
- Cable glands.
- Multi-hole gaskets.

Technical features

Power supply interface:	230V ± 10%
Protection:	IP55
Display:	LCD Display
Keyboard:	6 buttons
Digital inputs:	<ul style="list-style-type: none"> - float switch for dry-running protection - tank fill float switch - safety pressure switch
Analogue inputs:	pressure transducer 4-20 mA
Digital outputs:	general alarm, the display shows the type of alarm (see paragraphs 7.6. and 9.3.)
Connectivity:	RS485
Protections:	<ul style="list-style-type: none"> - dry-running protection - over-current - over-heating - under-voltage and over-voltage - short-circuit protection on the motor phase

Pushbuttons functions



Through this button you can start the pump.



Through this button you can stop the pump.



Through this button you have access to frequency converter programming parameters. If you already are on the programming function, by pushing this button you go up on the menu.



Through this button you have access to frequency converter programming parameters. If you have changed a parameters, by pushing this button you can confirm the indicated value.



Through this button you can increase parameters or to change the visualized parameter.



Through this button you can decrease parameters or to change the visualized parameter.

Interface

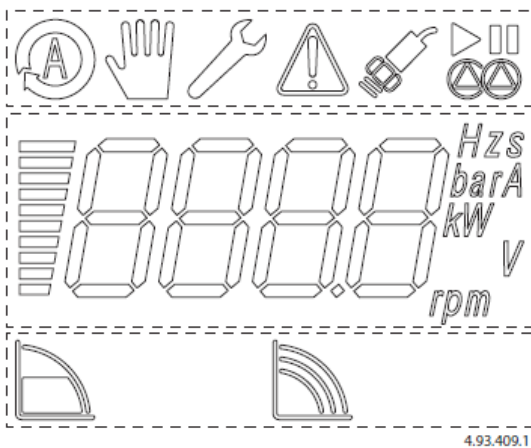

The graphic interface of the display is divided in three visualization areas:

- system icons
- display area
- operating icons

1.1.1. System icons.



AUTO MODE

The system is operating in auto mode.



MANUAL MODE

The system is operating in manual mode.



SET-UP MODE ACTIVATED

It shows that the set-up menu is activated

When an icon is blinking you are modifying a parameter. You can confirm with enter.

**ALARM**

It indicates that there is a fault on the system, the error number appears on the display area. When you are on the set-up mode the alarm icon will not appear.

**SENSOR STATE**

It indicates that the system is connected with the pressure transducer; if it is blinking there is a fault on the pressure transducer.

**PUMP STATE**

It indicates if the pump is running or in stand-by state.

**CASCADE MODE**

It indicates that the cascade control mode is working. The 2 upper symbols show if the pump is running or if the pump is in stand-by. The lower symbol informs if the pump is the master (lighted icon) or slave (blinking icon).

1.1.2. Display area

It is composed from an incremental bar proportional with the displayed value and its measure unit. The display is backlit, the light will be turned off after 20s of system inactivity.

1.1.3. Operating icons**Constant pressure mode**

The system keeps the pressure constant when the quantity of water requested by the user changes.

**Fixed speed mode**

The system works at a fixed speed that user can choose according to need.

Submersible pumps applications or long cables

To operate a submerged pump (or surface pump), where the distance from the inverter is more than 10 m, see paragraph 18.



Submersible motor must operate with a frequency between 30 Hz (minimum operating frequency) and 50 Hz (maximum frequency) for 50 Hz motors, and between 30 and 60 Hz for 60 Hz motors.



The running up time from 0 to 30 Hz and the running down time from 30 Hz and 0, must be as short as possible, according to the motor power to operate.

Installation

For easy assembling and disassembling of the frequency converter we recommend to respect the minimum distances as show in figure here below.

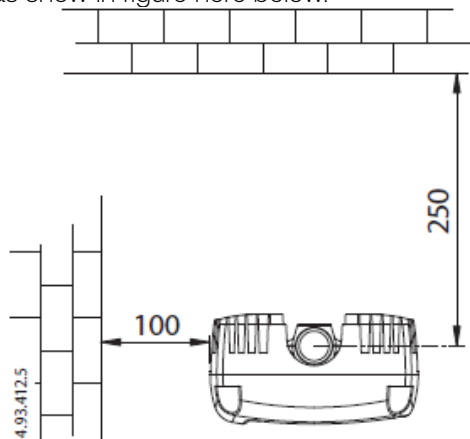

In case of reduced distances connect the frequency converter with the proper unions (see paragraph 16.3). Do not install the control panel in places exposed to direct sunlight or near sources of heat. Fasten the heatsink (a) to the pipe by means of the pipe housings (b1-b2) and the screws (c) in equipment.

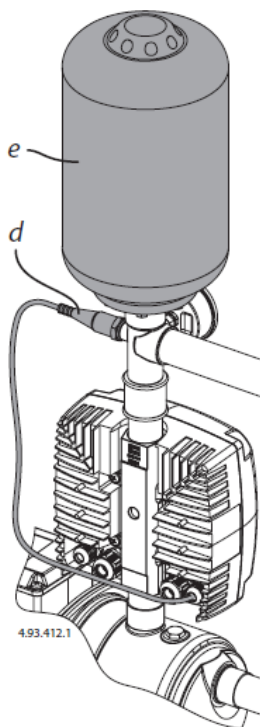
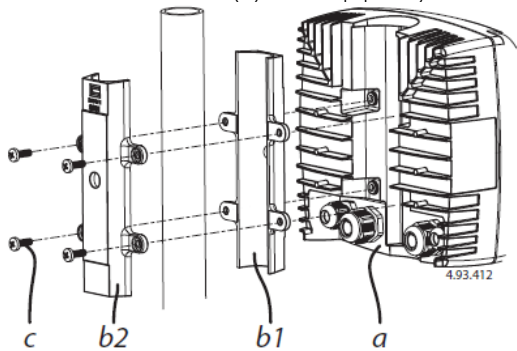

The pressure transducer (d) must be installed on the system. We always advise the installation of a small accumulator (e) (8 ltrs minimum) on the pump delivery side.

Electrical connection



Electrical connection must be carried out by a qualified electrician in accordance with local regulations.

Follow all safety standards.

The unit must be properly earthed (grounded).

Follow the instructions in the wiring diagram attached.



Once the electrical connection has been completed, remove any pieces of wire, sheath, washers or any other foreign bodies that may be found inside the frequency converter.



For the electrical connections on both the terminal board and the motor use cable with a maximum section of 2,5mm². We also advise the use of insulated pin terminals.



Bad connections may damage the electronic circuit.

Power supply line

Power supply line must comply with the provisions under paragraph 4.



If a differential protection is necessary, install a **type A differential switch**, protected against untimely activation and with threshold of intervention of 30 mA.

Electrical connection

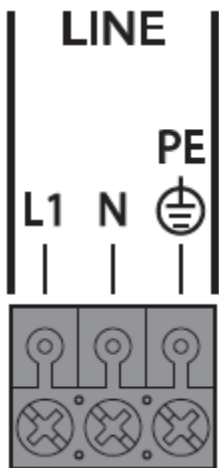

Motor connection

The power supply line of the electrical motor must be connected directly to the output terminal of the inverter.



To comply with the standards of electromagnetic compatibility, use a shielded three-pole cable (for Flowcon E MM models) or a shielded four-pole cable (for Flowcon E MT models) with external protection sheath.

The power supply line of the motor must never run parallel to the power line of the electrical panel.

Electrical connection

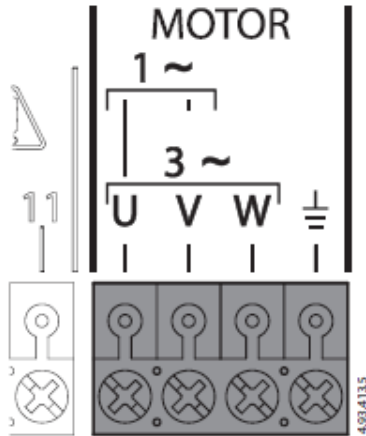

Pressure transducer

The pressure transducer is an analogical instrument with an output signal of 4-20 mA that continuously reads the pressure in a system.



Features:

Standards:	EN 50081-1, EN 50082-2.
Voltage:	8-28 V
Pressure range:	0-6; 0-10; 0-16 bar
Output:	4-20 mA
Working temperature:	da 0 a +50 °C
Protection:	IP 65
Hydraulic connection:	G 1/4 male
Weight:	~ 60 g

Electrical connection

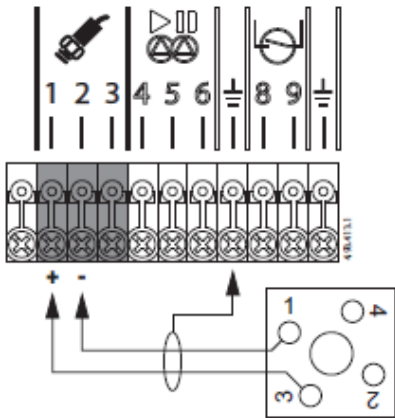

Pressure transducer terminal box in Flowcon E Inverter

Cascade mode

The Flowcon E frequency converters are prearranged for use in pressure boosting sets with up to 3 pumps in the following versions:

- Pressure boosting sets with 2 variable speed pumps
- Pressure boosting sets with 3 variable speed pumps
- Pressure boosting sets with 1 variable speed pump and 1 fixed speed pump (single-phase)

Cascade mode installation

Connect the frequency converters on the delivery pipes of the pumps, the installation must comply with the provisions under paragraph 6.

Connect the pressure transducer to the delivery manifold of the pressure boosting sets.



It is advised to install the pressure transducers on the same point of the delivery manifold and complete the installation with a pressure gauge.

Cascade mode electrical connection

Connect the supply cables to the motors and to the power supply following the instructions under paragraph 7. The power supply must comply the provisions of the paragraph 4-5.



The connection with the power supply must be made with interpositions of magnetothermal bipolar switches (one for each frequency converter).

For these frequency converters an earth leakage circuit breaker or ground fault circuit interrupter, type B.



This circuit breaker or interrupter must be marked with the following symbols:

Cascade connection with variable speed pumps

Electrical connection with 2 pumps

By means a proper cable make the connection of the clamps number 4-5-6 of both frequency converters.

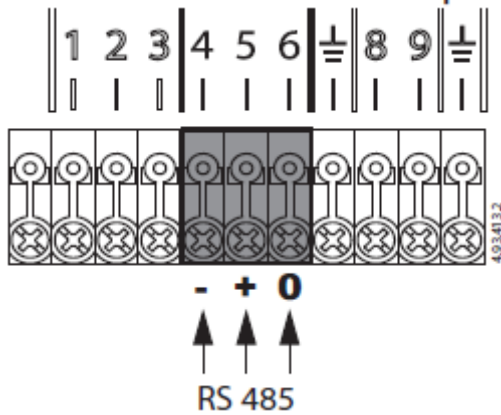

Electrical connection with 3 pumps

By means a proper cable make the connection of the clamps number 4-5-6 of each frequency converters.



User must provide a jumper connection into 1 frequency converter as shown in the picture.

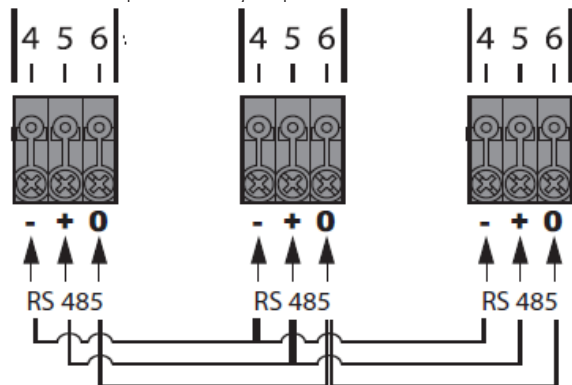

Check the correct connection sequence and check that terminals of each cable are connected on the clamp with same number.





To comply with the standards of electromagnetic compatibility, for cable length greater than 1 meter, it is recommend the use of a shielded cable with protection sheath connected on the ground of both frequency converters.

Cascade connection with 1 variable speed pump and 1 fixed speed pump

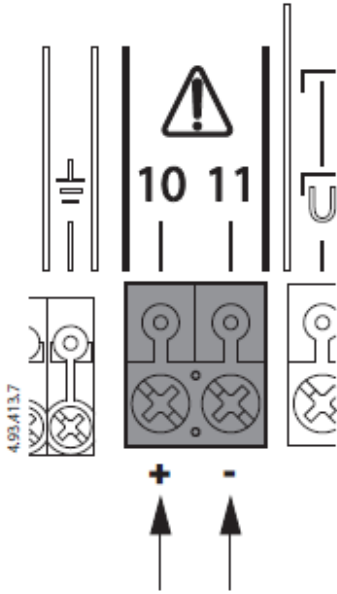
Connect the clamps 10-11 with a contactor with max.250 Vac and 450 mA maximum resistive current, connect to the contactor the power supply cable and the motor cable of the fixed speed pump.



 The connection with the power supply must be made with interpositions of magnetothermal bipolar switches with proper size and with a type A differential switch protected against untimely activation and with threshold of intervention of 30 mA.

 The use of the cascade mode with 1 fixed speed pump not allow connection of a remote alarm or a control panel remote alarm RA100.

Cascade mode programming

Pressure boosting sets with 2 variable speed pumps.

After the connection, change the AP09 parameter from OFF to UU for both frequency converters, define which frequency converter will work on master mode and for this frequency converter change the AP10 parameter from SLA (slave) to MAS (master).

Pressure boosting sets with 3 variable speed pumps.

After the connection, change the AP09 parameter from OFF to UU for both frequency converters, define which frequency converter will work on master mode and for this frequency converter change the AP10 parameter from SLA (slave) to MAS (master). Then parameter AP15 must be changed for each “slave” frequency converter. The first slave frequency converter must be set as “SLA1”, and the second slave frequency converter must be set as “SLA2”.

For the right behaviour of the booster set it is recommended to switch off and switch on all the frequency converter.

 This configuration define an address for each frequency converter, if not correctly configured, cascade mode will not work properly.

Pressure boosting sets with 1 variable speed pump and 1 fixed speed pump (single-phase).

After the connection, change the AP09 parameter from OFF to UF for the frequency converter.

Cascade mode plant starting

Check that all the cascade mode parameters are with the desired values, the parameters that can change the cascade mode operation are:

AP16	Cascade mode start fall pressure set-up
AP17	Cascade mode restart delay
AP18	Cascade mode fall pressure limit set-up

To do the plant starting follow the instructions under paragraph 12.

Float switch connection

To connect a float-switch connect to the connections 8-9 the cables of the float switch. The float switch can be used for:

- dry-running protection



if, in cascade mode, the frequency converter which is connected the float switch is failure, the float switch cannot shut off the pumps.

Electrical connection

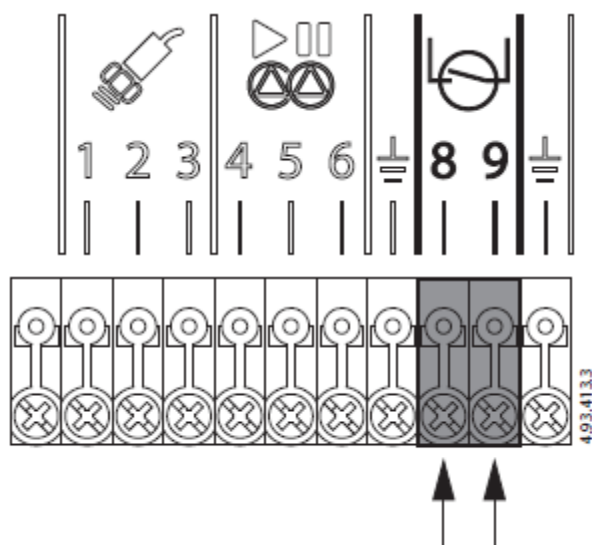

Remote alarm connection

Connect to the terminals 10-11 a possible remote alarm or the control panel for remote alarm RA100.

The remote alarm can be used to signal:

- error on the frequency converter (see paragraph 9.3.) (nO).
- the frequency converter is running (nC).



Operating limits: 250 Vac, 450 mA maximum resistive current.

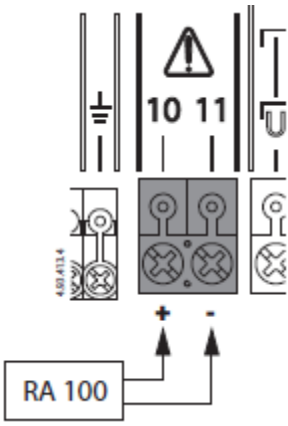

Electrical connection

Dry-running protection

The frequency converter is equipped with a dryrunning protection for the pumps. When the pressure on the system remain for a time higher than the dry-run time (AP05) lower than value of the dry-run pressure (AP07) the protection system stop the pump. It is possible the use of an external float switch for the dry-running protection (see paragraph 7.5.). In this case the pumps start with a delay time (in seconds) defined by AP19 (Digital input restart time), the time will be counted after the change of the float switch state.

For entering the programming mode see paragraph 10.

Parameters

On the frequency converter the following information are displayed:

- Parameters of pump status.
- Programming parameters.
- Alarms.

Parameters of pump status

They allow to visualize:

- the modulation frequency of the pump (basic display).
- the pressure of the system.
- the line absorbed current.

Starting form the basic display by pushing of the directional arrow (plus) or (minus) the other parameters are displayed.



Example:

Programming parameters

To display the programming parameters, select menu.

Will be displayed progressively:

UP - User settings: these are the basis settings that user can change.

AP - Advanced settings: these settings are available only to qualified personnel. To enter password is required (see paragraph 10.1.).

SA - Technical assistance settings: these are the advanced parameters, only technical assistance personnel are allowed to access this menu. Password is required (see paragraph 10.1.).

MA - Fixed speed mode activation: this allows activation of the fixed speed mode and the working frequency. Only qualified personnel are allowed to access this menu. Password is required (see paragraph 10.1.).

AE - Advanced parameters: this allows for the display of secondary parameters which can be useful for system diagnostics.

AE01	Software release
AE02	Supply voltage (V)
AE03	Last 5 faults

Supply voltage visualization example.

By pushing the menu button the UP parameter appears. Select the AE parameter by pushing the plus up to arrive at the correct **AE** parameter, confirm with enter.

Select the parameter **AE02** by pushing the plus button and confirm with enter.

Supply voltage is displayed.

UP – User settings

N°	Description	Standard	Modifications	Note
UP01	restart mode power failure [rA = automatic; rM = manual]	rA		
UP02	Nominal pump current (A)	0,1		
UP03	Nominal pump frequency (Hz)	50		
UP04	Direction of rotation [---3 = std rotation; E--- = inverted rotation]	---3		
UP05	Set point pressure (bar)	1,5		

AP – Advanced settings

To enter password is required (see paragraph 10.1.)

N°	Description	Standard	Modifications	Note
AP01	Pressure transducer set-up (bar) [sensor full-scale]	10		
AP02	Ramp down (s)	3		
AP03	Ramp-up (s) (fixed value for MM)	2 MT 0 MM		
AP04	Time before stop (s)	30		
AP05	Dry-run time (s)	10		
AP06	First dry-run time (s)	60		
AP07	Dry-run pressure (bar)	1,5		
AP08	System dynamic [1 = fast dynamic; 5 = slow dynamic]	3		
AP09	Cascade mode [oFF; UU = cascade mode with double inverter; dP = Twin pump UF = cascade mode with an inverter]	oFF		
AP10	Master/Slave setting MAS = master; SLA = slave	SLA		
AP11	Reset to factory set-up			
AP12	Digital input activation [0 = oFF; 1 = no; 2 = nC]	1		
AP13	Digital output activation [0 = oFF; 1 = on; 2 = no; 3 = nC]	0		
AP14	Restart fall pressure set-up (bar)			
AP15	Pump address	SLA1		
AP16	Cascade mode start fall pressure set-up (bar)	0,3		
AP17	Cascade mode restart delay (s)	10		
AP18	Cascade mode fall pressure limit set-up (bar)	0,6		
AP19	Digital input delay time (s) [float switch delay time]	30		

9.2.3. SA – Technical assistance settings

To enter password is required (see paragraph 10.1.)

N°	Description	Standard	Modifications	Note
SA01				
SA02				
SA03	Pressure PID (Proportional gain)	2,8		
SA04	Pressure PID (Integral time constant)	5,5		
SA05	Pressure PID (Derivative time constant)	5,0		
SA06	Min. run frequency (Hz)	30		
SA07	Max frequency (Hz)	60		
SA08	Set point pressure step up (bar)	0,3		
SA09	Pressure step up time (s)	3		
SA10	Pressure step up ramp (bar/s)	0,3		
SA11	Set point control ramp (bar/s)	0,4		
SA12	Carrier frequency	7010		
SA13	Singlephase starting frequency (Hz)	80		
SA14	Singlephase starting voltage (V)	195		
SA15	Nominal voltage (V)	220		

MAn – Fixed speed mode activation

To enter password is required (see paragraph 10.1.)

N°	Description	Standard	Modifications	Note
MAn1	Fixed speed mode activation	oFF		
MAn2	Working frequency [MAn2 ≤ UP03] (Hz)	45		

Alarms

N°	Displayed alarm	Causes
Er01	Blockage due to no water	The device is in failure due to no water. The system try to restart automatically. - One attempt every 10 minutes for 6 times. - One attempt every hour for 24 times. - One attempt every 24hours for 30 times.
Er02	Pressure transducer fault	Not connected cable, broken connection, pressure transducer spoiled.
Er03	Blockage due to low supply voltage	Supply voltage lower than 190V. - The system automatically restart when the clamp voltage is higher than 190V.
Er04	Blockage due to high rectified voltage	Supply voltage higher than 250V. - The system automatically restart when the clamp voltage is lower than 250V
Er05	Blockage for memory failure	
Er06	Blockage due to overcurrent in the electro pump motor	
Er07	Blockage due to overcurrent in the frequency converter	
Er08	Blockage due to direct short circuit between the phases of output terminals	
Er09	Blockage due to overheating	
Er10	Blockage due to overheating of the power module	
Er11	Blockage due to low voltage 24 V	
Er12	Stop for float switch intervention	The system will restart with a delay defined by AP19 from the state variation of the float switch. The control panel for remote alarm not report this alarm.
Er13	Internal hardware error	Contact the technical assistance
Er14	Cascade mode communication error	Check the RS 485 connection or that both pumps are enabled.



In case of multiple fault, scroll with the plus or minus buttons to visualize the fault sequence. In case of thermal block it is advised to check the causes that have created the problem before restart the pump operation.

Programming

To enter programming:

- Select menu.
- Use the plus or minus buttons to move to the programming parameter to be modified and select enter to confirm.
- Use the plus or minus buttons to move to the parameter to be modified and select enter to confirm, with the plus or minus buttons increase or decrease the value. From this moment the set-up icon start blinking until the value is confirmed with enter.
- To exit the program, push menu until you arrive on the basic display.
- When you go in the set-up mode the icon will appear.

Example of parameter variation.

In order to modify the set point pressure from 3.0 bars to a 2.8 bars:

- Select menu and then with the plus or minus buttons until you move to programming parameter UP.
- Confirm with enter and then with the plus or minus buttons move to the parameter UP05.
- Confirm with enter and then with the plus or minus buttons change the value up to the desired value. From this moment the set-up icon will start blinking until the value is confirmed with enter.
- To exit the program, push menu until you arrive on the basic display, when you are out from the set-up mode the icon will disappear

PASSWORD insertion

To enter a menu with password, four numbers appear on the display, the number to insert is blinking.

By pushing plus or minus buttons you can change the blinking value. If you confirm with enter the next number start blinking.

If the password is correct you can enter on the MENU, if the password is wrong the first number will restart blinking.

To exit the program, push menu until you arrive on the basic display, when you are out from the set-up mode the icon will disappear.

Please contact the office for passwords.

Parameters to check when starting up the unit

There are 4 programming parameters that need to be checked when the unit is started up:

- **Parameter UP02 NOMINAL PUMP CURRENT**

The nominal current of the pump must be set.



If the value input is inappropriate there is the risk of pump damage or to have an unexpected overcurrent alarm.

- **Parameter UP03 NOMINAL PUMP FREQUENCY**

The nominal frequency of the pump must be set.



If the value input is inappropriate there is the risk of higher current absorption or pump damage.

- **Parameter UP05 SET POINT PRESSURE**

The working pressure of the pump must be set.

If the value input is inappropriate for the needs of the system, the value can be increased or decreased using the plus or minus keys.



If during the first start-up of the unit, filling the system takes longer than 1 minute and the unit signals a dry-running alarm, Increase the parameter AP06, until the pressure rises above the set value and the pump remain on. (Make sure the pump are primed).

Vessel pressure



Once the new working pressure is entered, the tank pre-loaded pressure must be changed to be 2/3 of the working pressure (i.e. 4 bar working pressure, tanks to be pre-loaded at 2.7 bar).

Plant starting



ATTENTION: never run the pump dry not even for a short trial run. Start the pump after filling completely with liquid.

After completing hydraulic and electrical connection and checked the preloaded pressure (for booster set with membrane tank), start the plant as indicated below:

Prime the pumps (see the pumps instructions).

Pump with suction lift:

- Fill the suction pipe and the pump body by means of the plug hole located close to the delivery port of the pump.
- Fill the suction tube by pouring water through the plug hole on the suction manifold of the pump.

Pump with positive suction head:

- Open the gate-valve in the suction pipeline .With sufficient head, the water will overcome the resistance of the non-return valve fitted in the suction side of the pump and will fill the pump body. Otherwise, prime the pump with the plug hole near the delivery port.



Never run the pump for more than five minutes with closed gate valve.

Starting pump

When the frequency converter is switched on, the pump are not operating and on the screen appears OFF.

Press the play button to change the pump status from STOP to run. The pump starts up with the acceleration ramp set to reach the wished pressure.



When the motor starts turning, check the direction of rotation.

If the pump has been primed correctly, after a few seconds the pressure will begin to increase on the display.

If, after a few seconds, operation the pressure remains at 0.0, stop the pump by selecting stop as priming has not been carried out correctly and the pump is idling. Re-prime the pump and repeat the starting up procedure.

Inversion of the direction of rotation

To change the direction of rotation of the motor, push the button menu and then with the plus button move up to the programming parameter UP.

Confirm with enter and with the plus button move up to the parameter UP04, confirm with enter and by pushing of the plus button change the value, confirm with enter.

To exit the program, push menu until you arrive on the basic display, when you are out from the set-up mode the icon will disappear.

Operations

The frequency converter is programmed to manage the automatic operation of 1 or 2 pumps, all at variable speed.

Depending on user consumption, the pumps start to guarantee the amount of water necessary at the set pressure.

When one pump has reached 50 Hz and water requirements increase, the second pump will begin operations.

The pumps are protected against:

- Operation when dry, by means of a floating switch and level sensor
- Over/under voltage (frequency converter)
- Thermal overload (frequency converter)

Quick set point modification

If the frequency converter is operating in constant pressure mode it is possible to change the set point pressure without enter on the user parameter (UP menu).

Pushing the enter button for more than 5 seconds you will enter directly to the set point pressure (UP05 parameter).

By pushing of the plus or minus buttons change the pressure value and confirm with enter.

By pushing of the menu button the system will return to the basic display (see paragraph 9.1.).

Use of megaohmmeter

Megging of an installation incorporating the frequency converter is not allowed, because the electronics may be damaged. If megging is necessary, disconnect the frequency converter and use the megaohmmeter directly on the terminal box of the pump.

Maintenance



Inspect the tank pre-loaded pressure of the delivery vessel periodically.

Accessories

RA 100 Control panel for remote alarm.



RA 100

Dimensions: 110x150x70
 Power supply: 220-230 V single-phase

Signals all pump assembly malfunctions detected:

- No water intake.
- Assembly malfunction.
- Converter failure.

5-Watt flashing red light plus 75 dB - 3600 Hz acoustic alarm, for use in areas of loud noise, positioned in such a way as to be visible from a distance.

The control panel is fitted to an energized panel led and an alarm reset pushbutton.

Pipe housings kit

Pipe housings for G1, G1 ¼ and G1 ½ pipes.

For the G1 ½ version of the Flowcon E Inverter it is required change the screws assembled on the heatsink with the screws provided with the G1 ½ pipe housing kit.

Unions kit

Steel pipe with unions and pressure transducer arrangement.

Disposal



European Directive 2012/19/EU (WEEE)

Observe the local regulations and dispose of any control gear accordingly. This product contains electrical and electronic components and should be disposed of accordingly.

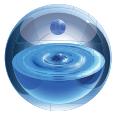

flowtech[®]
WATER SOLUTIONS

flowzone[®]

MEMBERS AREA

This section of the **flowtech**[®] website holds information exclusively for members. Members will need to log in to gain access to these pages.

Our member's will be granted exclusive access to our technical resource library. Within this resource is a wide range of product information including data sheets, technical drawings, O&M Manuals and training videos



flowcare[®]

AFTER SALES SERVICE

At **flowtech**[®] we operate a network of Service Engineers located throughout the UK who are supported by our offices located in and Greater Manchester. The distribution of engineers means that in the majority of cases we are less than 4 hours away from attending a customer call out.

We place great emphasis on providing technical back up to support our Service Engineers in resolving some difficult operational and technical issues. We pride ourselves on completing a project on time, within budget and never leaving a problem unresolved, or a customer waiting. This quality of service has made us the first choice for our customers.

FOR FURTHER INFORMATION OR ASSISTANCE

contact us

Flowtech Water Solutions are experts in water services and water booster sets. We have continuously supplied a wide range of standard and custom products since being founded in 1996.

MANUFACTURE & SUPPLY

TELEPHONE : 0333 200 1756

EMAIL: info@flowtech.org.uk

SERVICE & MAINTENANCE

TELEPHONE : 0333 200 1813

EMAIL: service@flowtech.org.uk

WEBSITE: www.flowtech.org.uk

ADDRESS : Unit 1 Lock Flight Buildings, Wheatlea Industrial Estate,
Wigan, Greater Manchester WN3 6XP United Kingdom

