



# flowboost<sup>®</sup>

Prime Single, Twin, Three & Four Pump

## OPERATION AND MAINTENANCE MANUAL

First Publication Date: 01/04/2023

Revision: 1

Revision Date:

# CONTENTS

General Information	3
Safety Information	4
Customer / Contractor Responsibilities	6
Pressure Settings on Start up	7
End of Curve Settings	7
Transport	7
Handling	7
Storage	8
System Specifications	8
Motor Energy Efficiency	8
Noise Levels	8
Applications and Use	8
Pumped Liquids	9
Conditions of use	9
Disposal and Environmental	9
Installation	10
Pipe Connections	10
Flexible Connections	10
Electrical Supply / Wiring	11
Tank Bases	12
Booster and System Isolation Valves	13
Suction and Discharge Pipework	13
Low Water Protection	15
Commissioning	18
Venting Pumps	19
Parameters	20
Warnings	26
Maintenance	28
Warranty	29

**Flowtech Water Solutions** are experts in water services and water booster sets. We have continuously supplied a wide range of both standard and custom products since being founded in 1996.

Now established as a major force in the market, partnering nationally with local councils, design engineers, mechanical contractors, developers, and end users.

Our company has a strong customer service ethos that has been shown in previous projects and the need to respond quickly to whatever our client's requirements are. Flowtech Water Solutions will handle projects from initial enquiry/tender to design and through to order placement and on-site commissioning followed by an annual maintenance contract if required.

### **Flowcare**

Flowtech operate a network of Service Engineers located throughout the UK. The distribution of engineers means that in the majority of cases we are less than 4 hours away from attending a customer call out.

We place great emphasis on providing technical back up to support our Service Engineers and in resolving some difficult operational and technical issues. We pride ourselves on completing a project on time, within budget and never leaving a problem unresolved, or a customer waiting. This quality of service has made us the first choice for our customers.

### **About this**

# Manual

Congratulations on purchasing your new Flowboost Water Booster Set. The following information is to assist you and to ensure your new unit is installed, operated and maintained correctly to comply with the manufacturer's warranty and to give a long working life to provide you with an uninterrupted, clean and safe water supply.

These instructions are to assist in the installation, Operation and Maintenance of a Flowboost Prime Booster Set. Please follow them carefully.

If, having read this Operation & Maintenance Manual, there is any doubt about any aspect of the equipment, installation or system please don't hesitate to contact our team on the contact details below.

**Flowcare (Service and Technical)**

**0333 200 1813**

**[service@flowtech.org.uk](mailto:service@flowtech.org.uk)**

**Flowtech (Sales)**

**0333 200 1756**

**[info@flowtech.org.uk](mailto:info@flowtech.org.uk)**

## Definitions of Safety Warnings and Precautions



### **WARNING!**

**Indicates a potentially hazardous situation which, if not avoided, can result in serious injury or death.**



### **CAUTION!**

**Indicates a potentially hazardous situation which, if not avoided. Can result in minor to moderate injury, or serious damage to the product.**

## Safety

# Information

It is essential that correct and safe working practices are adhered to at all times when installing, operating and/or maintaining any piece of equipment. Always consult safety data sheets, operating and maintenance manuals, Health & Safety legislation and recommendations and specific requirements of any equipment manufacturer, site controller, building manager or any other persons or organisation relating to the procurement, installation, operation and/or maintenance of any piece of equipment associated or in conjunction with any product provided by **flowtech** Water Solutions.

This document is intended for ALL installers, operators, users and persons carrying out maintenance of this equipment and must be kept with the equipment, for the life of the equipment and made available to all persons at all times. Prior to carrying out any work associated with the set it is essential that the following sheets are read, fully understood and adhered to at all times.

Equipment must only be installed, operated, used, and/or maintained by a competent person. A competent person is someone who is technically competent and familiar with all safety practices and all of the hazards involved.

Any damage caused to any equipment by misapplication, mishandling or misuse could lead to risk of Electrocution, Burns, Fire, Flooding, death or injury to people and/or damage to property dependent upon the circumstances involved. **flowtech** Water Solutions accepts no responsibility or liability for any damage, losses, injury, fatalities or consequences of any kind due to misapplication, mishandling or misuse of any equipment, or as a result of failure to comply with this manual.

Failure to install, operate, use or maintain the equipment in accordance with the information contained within this document could cause damage to the equipment and any other equipment subsequently connected to it, invalidating any warranties provided by **flowtech** Water Solutions to the buyer.

## Safety Warnings &

# Precautions

These instructions should be read and clearly understood before working on the system. Please read this manual carefully and all of the warning signs attached before installing or operating the equipment keep this manual handy for your reference. This equipment should be installed, adjusted and serviced by trained and qualified personnel. Failure to observe this precaution could result in bodily injury.



**WARNING!** - Install an emergency stop key separately from the isolator. Rotating shafts can be hazardous.



**WARNING!** - This equipment has a high leakage current and must be permanently fixed to a protective earth conductor.



**WARNING!** - When the run command is present on any of the inverters the motor may start without warning. If the inverters are set to 'AUTO' when there is a power failure, the pumps may start again when the power is reinstated.



**WARNING!** - Make sure that the input voltage is correct +/- 10% of 240V.

**WARNING!** - Be sure to install the unit in a room that is not exposed to direct sunlight and is well ventilated. These units are not designed for use in high ambient temperature, high humidity, excessive condensation, dusty, corrosive/explosive/flammable gas or salty environments. If it is necessary to install in these conditions, the unit must be protected sufficiently.



**WARNING!** - Do not connect the power source to any terminals except power connectors/isolators.



**WARNING!** - Hazard of electric shock. Disconnect incoming power before working on this unit.



**WARNING!** - Motor control equipment and electronic controllers are connected to hazardous line voltages. When servicing drives and electronic controllers, you may be exposed to components at or above the line potential. Extreme care should be taken to protect against shock. Dangerous voltage may exist after the power light is off.

*Wait more than 5 minutes after turning off the power supply before performing maintenance or inspection.*



**WARNING!** - The inverter should be protected separately against ground fault.

Where an installation has an RCD (ELCB) Earth Leakage trip for personnel protection. The leakage before tripping is usually permanently set around 30mA. The leakage through the Inverter EMC filters varies from around 20mA upwards, depending on the type of filter (Industrial or Domestic) and the size of the inverter.

There are different types of earth leakage trip, their characteristics and suitability for use with Inverter Drives varies as follows:-

There are three common types of RCD (ELCB):-

**Type A** - Detects AC and pulsating DC fault currents, provided the DC current reaches zero at least once every half cycle - This type can only be used with single phase drives.

**Type B** - Detects AC, pulsating DC and smooth DC fault currents - This type must be used with three phase drives.

**Type AC** - Detects AC fault currents only - This type should never be used with Inverter drives.

*Observe the regional regulations for electrical installation!*



**CAUTION!** - It is strongly recommended that all electrical equipment conforms to National Electrical Codes and local regulations. Only qualified personnel should perform installation, alignment and maintenance. **flowtech** Water Solutions reserves the right to alter the technical data in order to make improvements or update information.



**CAUTION!** - Failure to observe these rules will render the warranty invalid. The same applies to repair jobs and/or replacement. Your legal rights are not affected.



**CAUTION!** - The manufacturer declines all responsibility in the event of damage or injury caused as a result of tampering with the equipment.



**CAUTION!** - Do not switch on/off power supply to run/stop the motor/system! Start the unit only by using run button or external run command.

## **Customer / Contractor**

# **RESPONSIBILITIES**

It is the responsibility of the customer and/or the contractor:

- To ensure that anyone working on the equipment is competent and trained to carry out work on this equipment and is wearing all necessary protective gear and/or clothing. During maintenance operations and in any case when the machine is running in various modes, including its normal operating mode, avoid any clothing or accessories that may get entangled in the moving parts of the machine.
- Is aware of appropriate health & safety warnings.
- Has read the information in this section of the manual.

## **Pressure Vessel Isolation Valves**

Our pressure vessels are equipped with isolation and drain valves. It is imperative that during operation, the isolation valves are open and the unit can stop and start as designed. If the valves are closed it is effectively like running without a vessel at all. The booster set may run continuously, causing heat build-up and potential damage to the pumps, unit and surrounding pipework.

## Pressure Settings On Start Up

Although we take steps to ensure that all units that are supplied at reasonable starting pressures, when switched on, differences in supply chain and testing procedures may mean that the unit will be tested at a higher pressure than the system was designed for. Our commissioning engineers will stop the pumps on first switch on and reduce the starting pressure if required. The starting pressure on initial switch on, may not be suitable for the system pipework, fittings etc. and therefore the booster set should only be initially started by a “competent person” on site.

## End Of Curve Settings

Every booster set will have a minimum safe operating pressure

Inverters have settings within them to protect pumps against running with high current output and incurring damage due to low pressures. If the pressure is set too low then the inverter may stop due to over-current, but it will also slowly cause damage to the bearings and seals within the pumps themselves and cause noise in operation.

Every pump has its own NPSH (Net Positive Suction Head) margin, which is the minimum head of water pushing onto the suction of the pumps at a given duty. 1.5m is usually considered a general acceptable head of water in a tank.

## Transport

Flowboost Prime Water Boosters are built in our facility in Wigan, carefully packaged and sent via our expert couriers.

When the equipment is delivered, it should be inspected for any damage before taking receipt. If not entirely satisfied with the condition of the delivery, then we should be contacted immediately.

Note: Pictures of any damage and details will be preferred when contacting our sales team.

## Handling

When satisfied with the condition of the unit please check the weight before starting any lifting operations. The weight of the equipment is indicated on the rating plate.

During lifting, the machine will tend to rotate around the lifting point until it reaches a balanced position. Handle with care. Pay attention to the inertia of the object (oscillations in the direction of travel, difficulty in slowing down and stopping).

Pay attention to suspended loads. Do not stand under them. Pay attention to people, animals and objects in the work area. Use appropriate work area marking tools and delimiters, where necessary.

Do not operate the pump or let it pass over people.

## Storage

If the unit is going to be stored for any length of time before installation, then it must be stored inside, in a dry environment or protected from the elements. Transport packaging is not sufficient to protect from frosty conditions.

## Flowboost System Specification's

Limits of Use:

- Minimum ambient temperature: -10oC
- Maximum ambient temperature: +40oC
- Variation in the supply voltage: +/- 10%
- Humidity range: 5% to 95% without condensation and vapour

## Motor energy efficiency information

All Flowboost Booster pumps use motors compliant with reg. 640/2009 EC and subsequent amendments, therefore, compliant with efficiency class IE3 (three-phase versions with power greater than 0.55 kW).

## Noise levels

Every Flowboost Water Booster Unit that leaves our production facility is tested, inspected and signed off to our strict regime of Quality Assurance. Each unit should be no more than 70 dB in normal operation. If it is deemed that there is excessive noise, this may be due to damage or misuse and Flowtech Water Solutions should be contacted in the first instance.

## Applications and use

Flowboost Prime Water Boosters are designed for professional use in applications such as water supply from groundwater, pressure increase or irrigation. They can be used in the industrial, manufacturing or equivalent fields. They can also be used in the domestic, commercial, agricultural, artisan or tertiary sectors, for the same applications.

They must be installed in dry areas and protected from flooding.

These water boosters can work continuously at the maximum room temperature indicated on the rating plate.



## Pumped liquids

Clean liquids, compatible with the electric pump component materials. A liquid must have physical characteristics similar to those of clean water at room temperature (1030 kg/m<sup>3</sup> maximum density and 2 cPs (0.002 Pa.s) maximum viscosity. If these limits are exceeded, contact Flowtech Water Solutions.

Improper use can result in overheating of the machine and power cables, with consequences such as failure and potentially fire.

## Conditions of use

Maximum operating pressure: pump delivery pressure, obtained by the sum of the pump inlet pressure and the pressure increase supplied by the pump. See the rating plate. The maximum pressure at the appliance inlet is determined by the pressure increase created by the pump, so as not to exceed the maximum operating pressure (see the section dedicated to the calculation).

Flow rate and head: during normal operation, they must fall within the fields indicated on the rating plate. Under these conditions, optimal machine operation is achieved.

Room temperature: maximum 40 °C up to 1000 m altitude. If these limits are exceeded, contact **flow**tech Water Solutions.

## Non-permitted use

- Do not use the Flowboost Water Booster for applications other than those described above and, in any case, not authorised by **Flow**tech Water Solutions. Improper use may cause serious damage (including death) to people, animals, objects and the environment.
- Do not pump food liquids or human food products.
- Do not pump any liquids that are more viscous and/or denser than water.
- Do not use the machine in potentially explosive environments or with flammable liquids.
- Do not run the machine without any liquid.

## Disposal and Environmental Aspects

To dispose of the parts that comprise the Flowboost Water Booster Unit, you must abide by the current regulations and laws of the country where the product is used. In any event, do not throw away parts that may pollute the environment.

This item should NOT be disposed of with other household waste.

This stipulation only refers to the disposal of equipment within the European Union (2012/19/EU). It is the user's responsibility to dispose of the equipment by delivering it to a designated collection point for the recycling and disposal of electrical equipment.

## Installation

This unit is not designed to be installed outside and open to the elements. If there is no room inside the building it must be installed inside a suitable enclosure with necessary, frost protection.

**Flowtech** Water Solutions can provide a suitable enclosure to protect the unit, please contact our sales team on 0333 200 1756 for advice or a quotation.

## Pipe Connections

Locate the unit on a flat, level base with access to all parts for future maintenance. Where possible try to install the unit as close as possible to the water supply tank.

Ensure tanks are filled to just below the overflow, if filling manually or until the float valve automatically shuts off.

Remove protective covers from the inlet & outlet manifolds and proceed to cap off one end of each manifold using the Stainless-Steel caps provided, to suit site requirements.

Connect site pipework to the suction and discharge manifolds of the unit.

Care must be taken to size and install the correct size suction and discharge pipework in order to avoid water starvation and/or pump cavitation of the booster set, failure to do this may cause damage and this will not be covered under warranty. Explained in more depth, later in this manual.

Take care to ensure that the suction and discharge pipework is adequately supported to prevent any undue strain on the connections of the booster set.

## Flexible connections

Flowboost Water boosters are supplied with system commissioning valves and flexible connections as standard.

We cannot stress enough the issue of causing strain on the pump suction and discharge flanges. We appreciate that every installer will endeavour to align the booster to the system pipework but may still end up with a slight offset. A properly applied flexible connector can adjust for that offset. The flexible connectors that Flowtech provide are primarily used for noise attenuation to the system but as a secondary point, can be used for slight offset of booster and system pipework alignment.

These flexible connectors should NOT be used as 'elbows' and should not be used to route around any corners.

We recommend they are only bent through a maximum of 30°, dependent on the size of the bore.

See below.

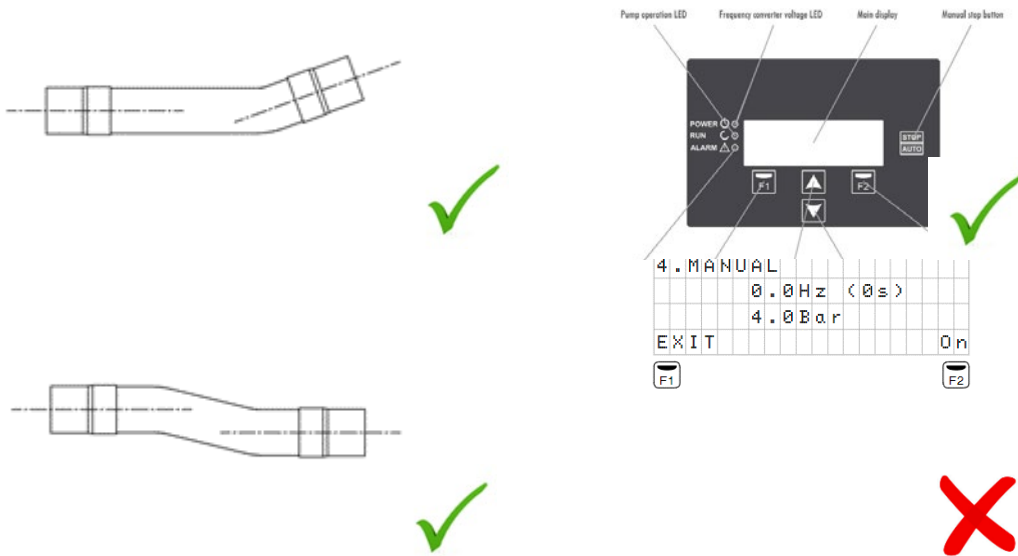

We supply various size flexible connections from 1 ¼” to 4” to suit our manifold sizes. The smaller sizes are more pliable but still should not be used as elbows. The bigger sizes are very rigid and may not bend very easily. As with any flexible connector, if they are overly bent through awkward angles they will kink and become unusable, as the bore will be reduced and may not allow the required amount of flow through the pumps or to the system.

If a **flowtech** supplied flexible connection is not going to be used, we would recommend that any flexible connection that is used is WRAS approved.

## Electrical Supply / Wiring

The unit must be completely electrically isolated before opening or removing panel/covers.

The connections must be exclusively performed by expert, authorised personnel and in compliance with legal obligations, current regulations, consolidated technical practices and the following provisions.

All wiring should comply with BS 7671 (18th Edition) and should cover input power and controls wiring. Considering that the unit has been in transit and then been subject to intrusive wiring from the installation electrician, we must check that all wiring is in place and correctly terminated within the unit. A commissioning engineer will check for loose wiring but also look for operational defects that may result from wiring being loose, not connected or overtightened. This is particularly important for the fire alarm and low water protection systems.

## Tank Bases

All Flowstore storage tanks must be positioned on a continuous, level and solid foundation. The foundation should be no smaller than the external footprint of the tank and be no more than + or - 2mm over any given metre. The foundation must not have any local debris or other items to the surface or damage to the tank base will occur.

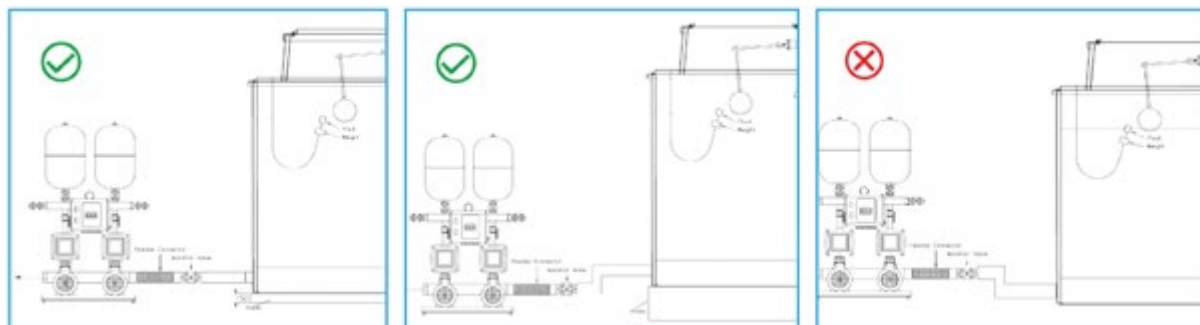

The purpose of a tank plinth or base is to support the tank but also to provide an elevated starting point where water can reach the booster equipment under gravity. Most tank bases will be around 150mm in height or higher if required for access to bolts underneath the tank.

Tanks should NOT be sat on the floor below the minimum inlet level of the booster set. They should also not be sat on any material that could damage the tank once weight is applied after filling with water.

Tanks should ideally be supported at 500mm centres and incorporate a marine ply board either internally within the body of the tank or externally from the tank and sat on top of the supports. Materials to support tanks can vary from timber, steel or concrete.

Water weighs 1kg per litre, plus the weight of the tank itself. Therefore, the base must be appropriate for the expected weight of the tank when full.

Any tank that is not adequately supported may cause leaks and subsequent damage to the tank and surroundings. The cause of these leaks may only appear long after the tank installation is complete.

## Tank Base Materials



### Timber

Although limited to a maximum of 5000 litres timber bases are a convenient, low-cost option. They are also ideal if there isn't a builder on site to provide a concrete base. These can be supplied quickly as they generally are stocked at our premises.

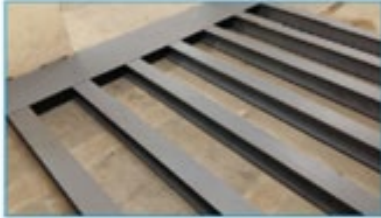

### Steel

Generally provided for sectional tanks as they are strong and can be adjusted with levelling shims. The steels must be laid 500mm apart and provide a perfectly level base. These can be provided as part of the tank package.



### Concrete

This option is provided typically to new installations where the builder has access to concrete, the base must be perfectly level and flat. Please contact us for detailed installation instructions.

## Booster and System Isolation Valves

Every valve on both the booster set or system has an important role to play in either, operation, commissioning or maintenance of the unit.

Operation of the booster set with any valves closed permanently, will certainly have a detrimental effect on the pumps and control system and invalidate the warranty.

Isolation valves should also be fitted to the incoming and outgoing pipework, so that the unit can be removed without the need to 'drain down' an entire system and test the unit in the case of a system with leaks.

The discharge valve alone is regularly used to prove that the unit stops when there is zero demand and that the pumps go to 'sleep' mode.

## Suction and Discharge Pipework

All pipework to and from the booster set needs to be adequately sized for the expected flow requirements of a particular building. This is extremely important on the suction side of the booster set as the water must flow towards the unit under gravity from the water tank. Any unnecessary restriction from pipework, filters, bends etc., will cause the pumps on the booster set to cavitate.

The ideal size of pipework will match the inlet manifold of the booster set. All fittings and connected items should be the same or larger if required.

**\*\*YOU CANNOT BE OVERSIZED ON SUCTION PIPEWORK\*\***

Discharge pipework is also key. Small bore or restrictive pipework will increase pressure losses through the system but can also cause issues with velocity noise for the occupants.

## Height of Pipework

The booster set is not designed to 'suck' or 'lift' water from a tank. The water should be able to freely get to the pump via gravity with as little restriction as possible.

The diameter of the pipe, tank connection sizes, bends, tee's, filters and valves all reduce the flow of water into the booster set.

Any suction pipework that is below the centre line of the booster set inlet will cause unnecessary airlocks and difficulty for commissioning and maintenance engineers. Air trapped in the suction pipe may only come through to the pumps when the booster is at full speed. This may happen long after the unit has been installed and commissioned.

The tank should always be raised in relation to the booster set.

## Pipework Support

Please ensure that pipework is adequately supported. A booster set is not designed to take additional weight.

## Restrictions

Suction pipework should not have the following:

### Excessive lengths of pipework

Up to 5m is generally acceptable. Long lengths may need to be increased in diameter.

### Unnecessary amounts of bends

These should be minimised where possible.

### Additional Connections

Pipework connected to other pump systems, which will starve the main unit. Other plant should have a direct connection to the water tank (sprinklers, other boosters, etc.)

## Low Level Water Protection

All Flowboost booster sets have a low water circuit incorporated for immediate cut off when water supply is lost. These are usually in the form of low water switch or switches, fitted to the water tanks. If these switches are not wired in or correctly set up, it is possible that the unit can still run dry. Although there is a form of electronic protection via the inverters, this is not a 'fool proof' system and does not provide an immediate stop. Air will get into the pumps and cause damage to seals, bearings and impellers. We strongly advise that units are not run before a low water protection strategy is put in place.

## Single Tank

The low level switch is imperative to protect the booster set against the effects of low water / dry running. Electronic protection alone within the equipment is not sufficient and damage to components may still occur.

The float switches Flowtech Water Solutions use are cable mounted Polypropylene float switches, which can also be retrofitted into existing tanks without the need to drain the tank first, see below.

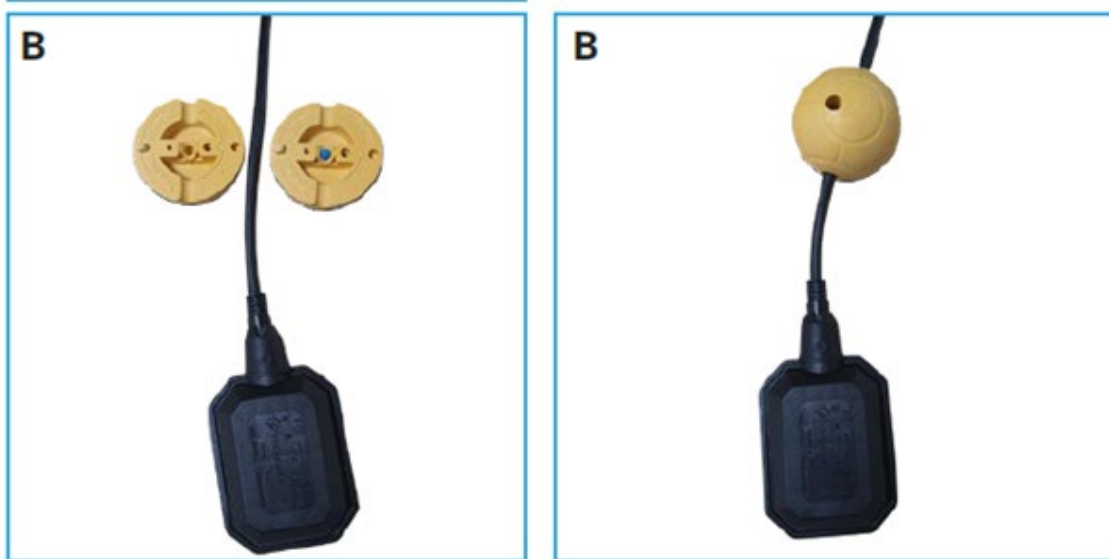

These have removable weights which negates the need to disconnect the wiring.

The low water switch and connectors should be positioned on the tank lid where it can be secure and not affected by other items within the tank. If possible, equally distant from the incoming mains and the suction connection to the booster. The cable should be fed through and secured with a cable tie once the correct length has been established. The float should open circuit in low water situation when wired correctly. Correct wiring to use from the cable is Black and Brown. Blue is not used.

## Tank Connector

Please do not fit the connector on the removable lid/access panel of the tank as the movement of the switch may stop the booster set. The tank connector must be installed through the top of the tank.

## Setting Cable Length

Setting the length of the cable/depth of water before the booster is shut down

The switch should be measured and set to hang 3 times the diameter of the suction pipe away from the suction connection (e.g 54mm suction = 162mm from the top of the suction connection).

This is to avoid a vortex drawing air into the booster unit.

## Setting the distance of the weight from the float

The weight should be fixed so a minimum of 10cm of cable is showing between the float and the weight (1m deep tank) and we would recommend that measurement on deeper tanks is adjusted to 10% of the depth of the tank.

The weight comes in 4 parts: two halves of the weight, a rubber locator and a screw.

Full instructions come with each float switch. Any questions please call our after-sales service department Flowcare on 0333 200 1813.

## Float switch connection

The Flowboost booster low water circuit terminals are 8 and 9 on any of our PRIME panels.

Only BLACK and BROWN wires are needed. These give a NC circuit to enable the booster to run, with no polarity on either side.

It is imperative that the low water circuit is wired in NC configuration (whether it be directly from the float switch or from the BMS control panel) so that if a cable is cut or the float switch fails it will shut the booster down.

Float switches are supplied in 5m or 10m lengths (20m upon special request).

These float switches can be cut/extended by site electricians.



## Divided/Dual tanks

Flowtech Water Solutions can provide a Flowcon Divided Tank Selection Panel which enables easier control when cleaning and maintaining cold water storage tanks connected to water boosters. They allow each tank to be individually isolated via a selector switch. This means that work can be carried out without stopping the booster set and the remaining side continues to be monitored. These panels can be retrofitted to any divided or dual tanks and connected into the booster.

Both level switches in divided and dual tanks need to be wired to the Flowboost panel in an 'Normally Closed' and 'Series' type configuration, so if either float switch changes state it will shut down the booster.

If wired to a BMS panel it is recommended there is communication between the BMS and the booster set and that the unit stops when the circuit is open.

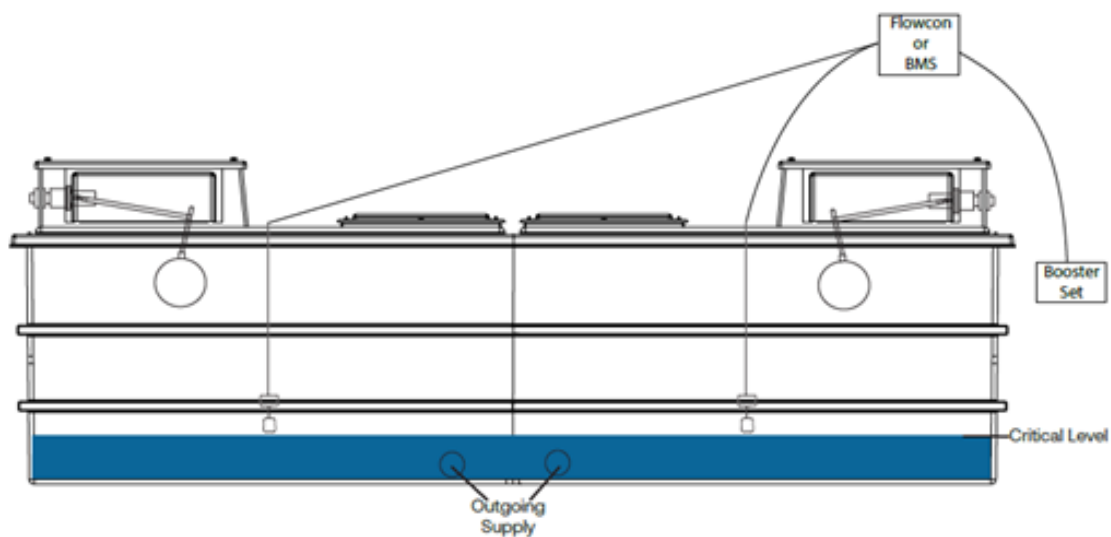

## Commissioning

Commissioning is provided to ensure that your Flowboost water booster is set up and configured to the system design duty. This provides an opportunity for the equipment to have the best possible start to its working life. The unit will be checked to have the correct digital settings and that any mechanical or electrical protection devices are operational. We are also able to ensure that the unit is in the correct position and that system and environmental conditions are as expected and not detrimental to long life operation.

Prior to requesting an engineer to attend the site for commissioning, the client must ensure that;

- The equipment has been correctly installed.
- Any necessary chlorination or other treatment has been completed.
- An adequate water supply and permanent electricity supply are available.
- The pipework in the building being served by the pump set is capable of accepting the generated pressures.

**CONTACT FLOWCARE SERVICE DEPARTMENT ON 0333 200 1813 IF THERE ARE ANY QUERIES OR CONCERNS**

All flowtech, Flowboost booster sets need to be site commissioned by a Flowtech Service Engineer or approved operator. This site commissioning is certified and also activates a 24-month warranty, which incorporates the “Flowtech Promise”.

The “Flowtech Promise” is a 24/7, parts and labour guarantee that Flowtech Water Solutions Ltd, will respond to any genuine warranty event where water has been lost to site as a result of faulty equipment or assembly.

This is in association with the standard Flowtech Warranty terms that are offered for non-emergency issues.

***Please Note:***

***Booster sets should NOT be switched on or run before a commissioning engineer is in attendance. Any damage or evidence of incorrect operation, prior to a commissioning visit, will invalidate the warranty and any rectification works or replacement equipment will be chargeable.***

If it is essential that water is provided to a building or system, before an engineer can attend, we would advise that this is totally at the 'users' risk and any subsequent damage to the equipment, system or building fabric, will not be the responsibility of Flowtech Water Solutions Ltd.

We would strongly advise that we are contacted before any unit is switched on and a minimum criterion is met in order to ensure the safety of the operator and the long-term longevity of the equipment. Although advice will be given by our Flowcare Service and Maintenance team, it remains the responsibility of the operator as to whether the equipment is made live to the water system.

## Venting of Pumps (Horizontal and Vertical)

All pumps **MUST** to be vented before operation.

All pumps should be completely free of air and should be vented on initial start-up.

Pumps **MUST** be isolated and stopped before venting.

### *Horizontal pumps*



### *Vertical Pumps Above 4kw*



The coupling guard will need to be removed to gain access to the bleed screw.

This operation should be repeated after around 10 minutes of operation as air can be brought through from the suction pipework or trapped between the pump impellers. Failure to do this may cause damage to the pump's mechanical seals and bearings. This in turn may cause noisy operation and leaks from the unit.

## Parameters:

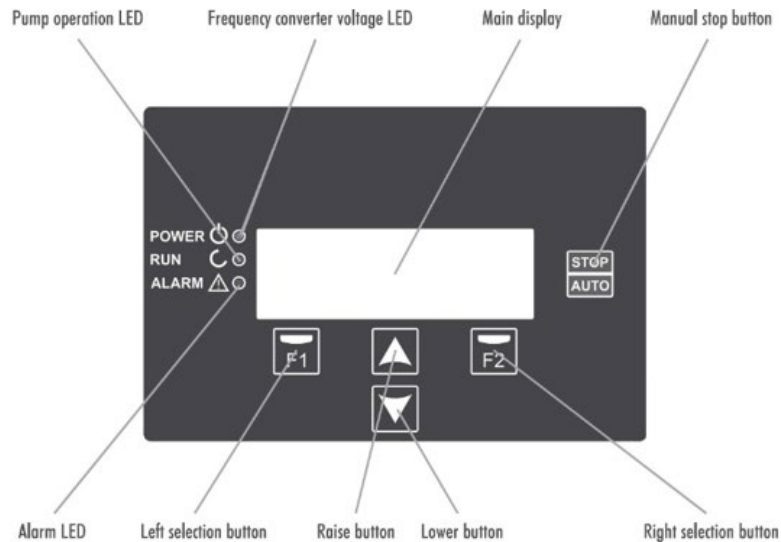

## Operation Mode

### A. *Single pump unit:*

The inverter has its own pressure transducer which reads the pressure in the system (Bar) and varies the speed of the pump in relation to the 'PRESSURE SETPOINT' (Parameter 1.1).

When demand increases and the system pressure drops the pump will start, according to 'START UP DIFFERENTIAL' (Para 1.7) to increase the pressure towards the 'PRESSURE SETPOINT' until it is reached.

When this is reached, the inverter will slow the pump until it gets to a minimum speed 'STOP FREQUENCY' (Para 1.6) set upon commissioning.

If there is still a demand on the system, then the inverter will control the speed of the pump to keep up.

If the demand ceases, the inverter will run the pump at a minimum speed for a set length of time, set in the 'MAIN PUMP STOP DELAY' (Para 5.12) factory set to 10 seconds.

### B. *Multi pump unit:*

When there are 2 or more pumps connected on the booster network, the pressure is regulated in the same way as a single pump, but the software in the inverter will decide which pump to start in an alternative order when the demand increases (Duty pump).

The software will calculate the best pump to run with regard to:

- Last pump run (e.g when Pump 1 stops, the next pump to start will be Pump 2)
- Running hours. If one pump has ran significantly more than the others, it will be rested and the system will try to equalise the pump run hours.
- Pump trip. If a pump has tripped, one of the other pumps will automatically start. In the event of a pump trip or inverter fault alarm whilst running, another pump will start automatically, straight away. If any running pump exceeds the 'MOTOR CURRENT' (Para 1.4) the inverter will limit the speed of the motor to avoid its deterioration, maintaining the current (AMPS) being used to 'MOTOR CURRENT', thus the system will continue to receive flow from the booster, not at the 'PRESSURE SETPOINT' but at a somewhat lower pressure.

## Initial Parameters

Parameters		Unit	Description
1.1	Working Pressure	Bar	Required system pressure
1.4	Motor Current	Amp	Maximum motor current (Amps)
1.5	Rotation Direction	N/A	Change the rotation of the motor by changing this parameter from 0 to 1
1.6	Stop Frequency	Hz	The pump will stop when the inverter has been working for a certain time (see parameter 5.12)
1.7	Start-up differential	Bar	The differential at which the pump will start below parameter 1.1 (above)

## information, (read only)

We strongly recommend that these parameters are not adjusted without first contacting our after-sales service department, Flowcare on 0333 200 1813.

Parameters		Unit	Description
2.01	Module Temperature	°C	This indicates the temperature the electronic module of the inverter.
2.02	Analogue Signal 1	mA	This indicates the value in mA of the pressure transducer 1. This data will be 4 mA for 0 Bar and 20 mA for the upper limit of the transducer connected.
2.03	Analogue Signal 2	mA	This indicates the value in mA of the pressure transducer 2. This data will be 4 mA for 0 Bar and 20 mA for the upper limit of the transducer connected.
2.04	0-10V Input	V	This indicates the value of the 0-10V signal if it is enabled in one of the inputs.
2.05	Motor Thermistor	kohm	This indicates the value of the NTC/PTC signal if it is enabled on settings.
2.06	Voltage Hours	Hours	This indicates the total number of hours the inverter has been connected to an electricity supply.
2.07	Hours Worked	Hours	This indicates the total number of hours worked (providing an output voltage) of the inverter.
2.08	Start-Up Number		This indicates the total number of start-ups from zero that the unit has made.
2.09	Digital Input 1		This indicates whether digital input 1 is ON or OFF.
2.10	Digital Input 2		This indicates whether digital input 2 is ON or OFF.
2.11	Digital Input 3		This indicates whether digital input 3 is ON or OFF.
2.12	Digital Input 4		This indicates whether digital input 4 is ON or OFF.
2.13	Relay 1 Output		This indicates whether the relay 1 output is ON or OFF.
2.14	Relay 2 Output		This indicates whether the relay 2 output is ON or OFF.
2.15	Software Version		Version of the unit software.
2.16	Cons. Power Of Pump	W	Instantaneous power consumed in output terminals toward pump.
2.17	Cons. Power Of Group	W	Power consumed instantaneously by all of the pumps.

## Alarm Log

Parameters section 3.01 – When you access the log menu you will find a list in chronological order of alarms that have been triggered on each pump, indicating the date and the time they occurred.

3.01	ALARM	F04							
		VOLTAGE							
	10/02/16	-	12:19						
EXIT									



Use the arrows to move forward or back to view the different alarms that have been triggered.

Press F1 to exit this menu.

## Manual Mode

Speed and operation tests can be carried out manually through this menu. When you access this menu, regardless of the status of the system, the inverter from which you are accessing will stop the pump.

When you enter this menu, this screen appears:

4.MANUAL									
		0.0Hz	(0s)						
		4.0Bar							
EXIT								On	



The display will show the frequency, an operation timer and the pressure at that precise moment read by the transducer.

When you press the F2 key (On) the motor will start, and you can increase or decrease the frequency using the arrow keys. At the same time, the countdown begins for 2 minutes of operation. If you do not press any keys, after 2 minutes the motor will stop automatically.

If you press the F2 key whilst the pump is running, the countdown will be increased to 15 minutes, 30 minutes, 1 hour, 2 hours, 4 hours, 8 hours, up to a maximum of 24 hours.

Press F1 to exit, stop the motor and return to the wait screen of this menu.

**WARNING! - Improper use of the manual mode can cause overpressures in the installation.**

## Advanced Parameters

We strongly recommend that these parameters are not adjusted without first contacting our after-sales service department, Flowcare on 0333 200 1813.

Please use this table for information only.

Parameters		Unit	Description
5.01	Language		Select the language for the menu and warnings
5.02	Units of pressure	Bar	Units of working pressure on display
5.04	Transducer min value (4 mA)	Bar	Value of pressure transducer at 4mA
5.05	Transducer max value (20 mA)	Bar	Value of pressure transducer at 20mA
5.08	Minimum frequency	Hz	Minimum frequency at which the pump is allowed to work
5.09	Maximum frequency	Hz	Maximum frequency at which the pump is allowed to work
5.10	Proportional boost	Bar	Pressure boost at the maximum frequency of the pump
5.11	Max No. pumps on		Maximum number of pumps that can function in the system simultaneously
5.12	Main pump stop delay	Sec	When the duty pump reaches setpoint (parameter 1.1) and the speed drops below the stop frequency (parameter 1.6), the pump will stop after this set time
5.13	Auxiliary start frequency	Hz	When the duty pump reaches this frequency it sends a command to an auxiliary pump to start up
5.14	Aux start delay	Sec	Time from the moment the condition of parameter 5.09 occurs until the auxiliary pump starts
5.15	Aux stop delay	Sec	Time from when a system of two or more pumps is working below parameter 1.6 until the auxiliary pumps stop
5.16	Changeover time	Hours	Time period for changeover between pumps
5.17	Pump kick interval	Hours	Time period for periodic start-up of pump. If the pump is inactive for this set time period, it will rotate at minimum frequency for 2 or 3 times
5.18	Digital input 1		This is used for the tank low water level input
5.19	Pressure input 1	Bar	Not used
5.22	Digital input 2		System fill from empty input, from control panel PCB
5.23	Pressure input 2	Bar	System fill from empty setpoint. Set by commissioning engineer
5.26	Digital input 3		Fire mode input, from control panel PCB. Connected to building fire alarm
5.27	Pressure input 3	Bar	Fire mode setpoint. Set by commissioning engineer
5.30	Digital input 4		For future development
5.31	Pressure input 4	Bar	For future development



Parameters		Unit	Description
5.35	Slave 1V pressure setpoint	Bar	If a 0-10V device is installed, here you can set the pressure value for the 1-volt signal. *This parameter is available when any of the digital input is set to Slave 0-10V
5.36	Slave 9V pressure setpoint	Bar	If a 0-10V device is installed, here you can set the pressure value for the 9-volt signal. *This parameter is available when any of the digital input is set to Slave 0-10V.
5.41	Relay output 1		Output signals for BMS connection. OFF: The relay is never activated. Alarm (NO): The relay closes on alarm. Alarm (NC): The relay opens on alarm. Start: The relay is energised when the unit is running. Clock (NO): The relay closes depending on the time data programmed in parameters 5.44 to 5.48. Clock (NC): The relay opens depending on the time data programmed in parameters 5.44 to 5.48. Dry running: The relay is energised if the inverter detects dry running. External stop: The relay is energised when there is an external stop. (For this condition we must have programmed a digital input as "Local Stop"). Overpressure (NO): The relay closes if there is overpressure alert (parameter 5.49). Overpressure (NC): The relay opens if there is overpressure alert (parameter 5.49).
5.42	Relay output 2		As above
5.43	Schedule operation 1		In this parameter you can choose not to have a schedule program (OFF) or the days of the week that you want this program to run. You can choose between whole weeks (M-Su), weekdays (M-F), weekends (Sa- Su) or individual days. The schedule program will act on the output relay programmed for this purpose.
5.44	Program start time 1		Start time of schedule program 1
5.45	Program stop time 1		Stop time of schedule program 1
5.46	Schedule operation 2		Same as parameter 5.43 but for a second schedule program
5.47	Program start time 2		Start time of schedule program 2
5.48	Program stop time 2		Stop time of schedule program 2
5.49	Overpressure alert level		Parameter to set the maximum pressure value of the Hydraulic system



Parameters		Unit	Description
5.54	Dry running alarm active		Enable or disable the low water level alarm. When the inverter detects low pressure in relation to the speed of the motor it will stop the pump. The inverter will attempt to start the pump by the following sequence: 5 minutes, 15 minutes, 1 hour, 6 hours or 24 hours. The display shows the remaining time until the next start attempt. Pressing F2 will reset the alarm, as long as the fault condition has been rectified. If after the 24-hours the alarm condition has not been rectified, the drive will lock indefinitely until F2 is pressed.
5.56	Dry running alarm delay	Sec	Time from when the system calculates a low water level until the moment the alarm is activated.
5.57	Burst pipe alarm		Enable or disable the detection of a broken pipe.
5.58	Voltage alarm active		Enable or disable the alarm due to a power cut.
5.59	Motor thermistor type		Select the type of motor thermistor available for motor protection.
5.60	Motor thermistor level	kOhm	Set the trigger level of motor thermistor connected.
5.61	Parameter lock		Editing the values of this parameter is locked after factory testing.
5.62	Set date and time		Select "YES" to edit the date and time. Once editing is completed, the parameter returns to "NO".
5.63	Stop frequency search wizard		Select "YES" to start the Stop frequency search wizard.
5.64	Factory default rest		This will reset the inverter to default settings. Password is required.

## Fine Tuning Parameters

Menu 6 is locked by a password. Our service engineers may adjust these parameters and our after-sales service department may require you to access if contacted. Flowcare, 0333 200 1813.

Please use this table for information only.

Parameters		Unit	Description
6.01	Proportional constant		
6.02	Integral constant		
6.04	Switching frequency	kHz	
6.05	Stop manoeuvre frequency	Bar	
6.06	Speed of stop manoeuvre		
6.07	MODBUS address		
6.08	MODBUS baudrate	kbps	
6.09	MODBUS parity		
6.10	Alarm log reset		
6.11	Start-up number log reset		

## Warning and Fault Indications

A table specifying the current state of the system operation, according to visual warnings that are shown using both the LEDS and the main screen can be found below:

<b>Warning</b>	<b>Reason</b>	<b>Explanation / Solution</b>
The POWER LED blinks	The Inverter is not in automatic running mode.	Check that there is no manual shutdown (AUTO/STOP button on the keypad), a remote stop (auxiliary input active remote stop) or a general stop of the network of Inverters (occurs when any general critical parameter is being modified).
The RUN LED blinks	The Inverter is in the process of stopping the pump.	
The ALARM LED blinks	The start-up wizard is running.  The pump is in a state of alarm (indicated on the display).	The LED will stop blinking once the initial configuration wizard has finished.  Consult the section on Alarms in this manual to resolve the incident.
The current frequency data blinks	The Inverter is limiting the speed of the motor due to a high temperature in the electronics, in addition to excessive consumption of the motor.	Consult the section on Alarms in this manual to resolve the incident. Check the Inverter is properly ventilated.
The stop frequency data blinks	The stop frequency calculated exceeds the maximum frequency permitted for pump operation.	We recommend running the stop frequency setup wizard again (find the stop frequency wizard on 5. ADVANCED PARAMETERS). If this warning persists after running the wizard again, you must reduce the working pressure, as the pump that is connected will not be able to reach it.
The current consumption data blinks	The Inverter is limiting the speed of the motor due to excessive consumption.	Check that the motor current is the same as indicated on the specifications plate.
Next to the current pressure data, there is an asterisk that blinks	The Inverter with this warning does not have any pressure transducer connected. If there is a transducer connected, it is not connected with the correct polarity.  The transducer's reading has a difference of 0.5 bar from the other transducers connected on the network of Inverters.	Disconnect the transducer from the electrical terminal block and invert the polarity of the connecting cable.  We recommend changing the transducer because it is not reading correctly.

<b>Warning</b>	<b>Reason</b>	<b>Explanation / Solution</b>
ALARM F01 OVERCURRENT	Indicates excessive consumption in the motor.	Check that the nominal consumption data has been entered correctly.  Check that the pump rotates freely with no obstructions.
ALARM F02 SHORT CIRCUIT	The motor is short circuited or has burnt out.  Not all wires have been connected.  Internal fault in the Inverter	Disconnect the motor from the Inverter and check that the message disappears. If this is not the case, contact Flowtech Water Solutions.  Check that all the cables of the motor are correctly connected to the motor itself and to the Inverter. Also check the correct wiring of the Inverter's power supply.  Contact your Flowtech Water Solutions.
ALARM F03 EXCESS TEMPERATURE OF THE MODULE	The power module has reached a very high temperature, Compromising it's reliability.	Ensure the ambient temperature does not exceed the extremes set out in this manual.  Ensure the pump has a fan and that the fan cover has been fitted.
ALARM F04 INPUT VOLTAGE	The Inverter is not receiving electric current, or is outside of the upper and lower limits.	The electrical supply to the Inverter has been interrupted.  The electrical connection cable from the mains electricity to the inverter has been disconnected.  The electrical voltage entering the Inverter is outside the limits specified in the technical data section.
ALARM F05 TRANSDUCER	The Inverter does not receive a correct reading from the pressure transducer.	The pressure transducer is wired in the frequency converter with the polarity reversed.  The pressure transducer is broken.  The pressure transducer has a range other than 4-20 mA.

<b>Warning</b>	<b>Reason</b>	<b>Explanation / Solution</b>
ALARM F06 MOTOR FAULT	The motor is short circuited or has burnt out.  Fault/poor connection of the phases	Disconnect the motor from the Inverter and check that the message disappears. If this is not the case, contact your Flowtech Water Solutions.  Some of the cables that communicate the motor with the inverter are not making good electrical contact.  The motor is connected to receive a voltage other than that provided by the Inverter.  The consumption of the input phases is not balanced.
ALARM F07 LOW WATER LEVEL	The Inverter detects that the pump is working partially at no load.	Ensure the pump aspirates the fluid correctly.
ALARM F08 BURST PIPE	The Inverter detects that the pump is working at a very low pressure and at a speed high for a time.	Check that the water network has no leaks greater than those required for regular demand.

## Maintenance

Maintenance of the Water boosting equipment you have purchased is in your best interests and that of the end user. As this will ensure the equipment sustains a long working life and continues to supply clean, safe water to whomever it serves.

We recommend that the equipment is maintained at least once every 12 months. However, we would also recommend the frequency of servicing is shortened with equipment supplying higher usage or high dependant systems, e.g. factories or production lines, to 6 or 3-monthly intervals.

The benefits of regular routine maintenance are;

- Longer working life, by up to 40%.
- Less frequent breakdowns and water outages.
- Comply with insurance policies and local regulations.
- Peace of mind that the equipment is running at peak performance.

As part of our maintenance packages, our experienced and friendly Flowcare After-Sales Service Division, can inform, advise and answer any questions regarding the water boosting equipment. Each time one of our highly skilled Service Engineers attends to maintain the equipment, they will

look over the complete installation. Ensuring the pumps are performing as they should, the control vessel is charged correctly and check the cold-water storage tank is clean. Inform of any defects, repairs or suggestions they have. Then complete a report detailing the condition of the equipment, work carried out, recommendations and advice for the equipment, installation and the system it is serving.

***With our Flowcare maintenance agreements you can be sure that your equipment is in the very best hands.***

## Warranty Agreement

As part of the contract of sale when this Flowboost Water Booster PRIME was purchased there is a warranty agreement that is included within. This acts as a form of contract with the original purchasing customer.

Flowtech Water Solutions will replace, repair and make good any genuine claims of defects of the equipment and any damage caused by the equipment, at our cost as long as all the recommendations and stipulations set out in this Operation and Maintenance Manual have been met and there are no external factors contributing to the defects or damage described. We will be allowed to carry out our own investigation before a decision is made as to whether a claim is deemed to be covered or not covered under our warranty terms. If we deem a genuine warranty claim then it will be our decision as to which parts will need to be replaced or repaired and if any building damage has been caused, whether it was a direct result of our equipment failure.

Parts which are assembled in our factory and shipped as one complete unit will have a warranty period of 24 months from date of commissioning or 30 months from date of invoice, whichever comes first.

Cold water storage tanks direct from our factory or sent from our supplier straight to site will have a warranty period of 12 months, from the date of assembly by ourselves, our approved contractors or suppliers. As long as they have been filled with water before 10 days has expired from the date of assembly and are kept full.

# Declaration of Conformity

## UKCA & CE

**This declaration of conformity is issued under the sole responsibility of Flowtech Water Solutions Ltd in accordance with the following directives and Statutory Instruments:**

- Machinery Directive (2006/42/EC)
- S.I. 2008:1597 : The Supply of Machinery (Safety) Regulations 2008
- Eco-design (2009/125/EC) EU no 547/2012 (water pump) if MEI marked
- S.I. 2010:2617 : The Ecodesign for Energy Related Products Regulations 2010
- EMC Directive (2014/30/EU)
- S.I. 2016:1091 : Electromagnetic Compatibility Regulations 2016
- Low Voltage Directive (2014/35/EU)
- S.I. 2016:1101 : Electromagnetic Compatibility Regulations 2016
- RoHS Directive (2011/65/EU)
- S.I. 2012:3032 : Restriction of Certain Hazardous Substances in EEE Regulations 2012
- Radio Equipment Directive (2014/53/EU)
- S.I. 2017:1206 : Radio Equipment Regulations 2017
- Pressure Equipment Directive (Directive 2014/68/EU)
- S.I. 2016:1105 : Pressure Equipment (Safety) Regulations 2016

We hereby declare that the equipment:

Product Ranges - Flowtech Cold Water Booster Sets:

**Flowboost, Flowpac, and Flowpac Compact**

Is in conformity with the applicable requirements of the following documents:

- EN 809:1998+A1:2009: Pumps and pump units for liquids - Common safety requirements
- EN 60204-1:2018: Safety of machinery - Electrical equipment of machines - Part 1: General requirements
- EN ISO 12100:2010: Safety of machinery - General principles for design
- EN 61000-6-2:2019: Electromagnetic compatibility (EMC) — Part 6-2: Generic standards
- EN 61000-6-4:2019: Electromagnetic compatibility (EMC) — Part 6-4: Generic standards

I hereby declare that the equipment described above has been designed to comply with the relevant sections of the above referenced specifications. The unit complies with all applicable essential requirements of the directives.



Nigel Freeman, Director

Flowtech Water Solutions  
Unit 1 Lock Flight Buildings  
Wheatlea Road Industrial Estate  
Wigan, WN3 6XP



[info@flowtech.org.uk](mailto:info@flowtech.org.uk)

0333 200 1756

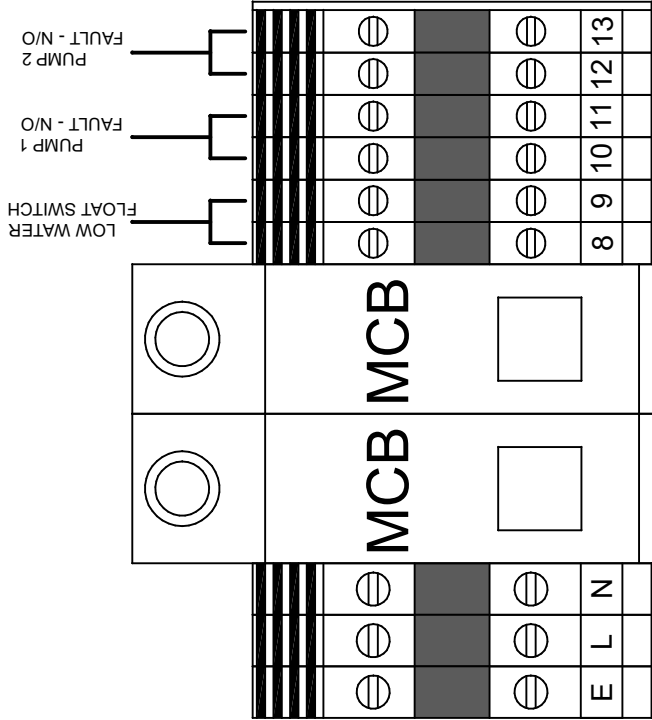

Common Fault connections  
 Link Terminals 11 & 12 and connect  
 BMS to terminals 10 & 13

DRAWING NO.

**FB.PRIME.2V.1-WD.R2**

TITLE

**Flowboost PRIME 2V.1 Wiring Diagram**

TEL

0333 200 1756

Notes:

ALL DIMENSIONS ± 1mm UNLESS STATED OTHERWISE



DRAWN BY

**P. EARL**

DATE

**18/04/2023**

EMAIL

info@flowtech.org.uk

WEBSITE

www.flowtech.org.uk



Please note that the drawing must be read in conjunction with the installation & operating guidelines

Scale

**1:1**

**A4**

ALL DIMENSIONS IN MM - DNS

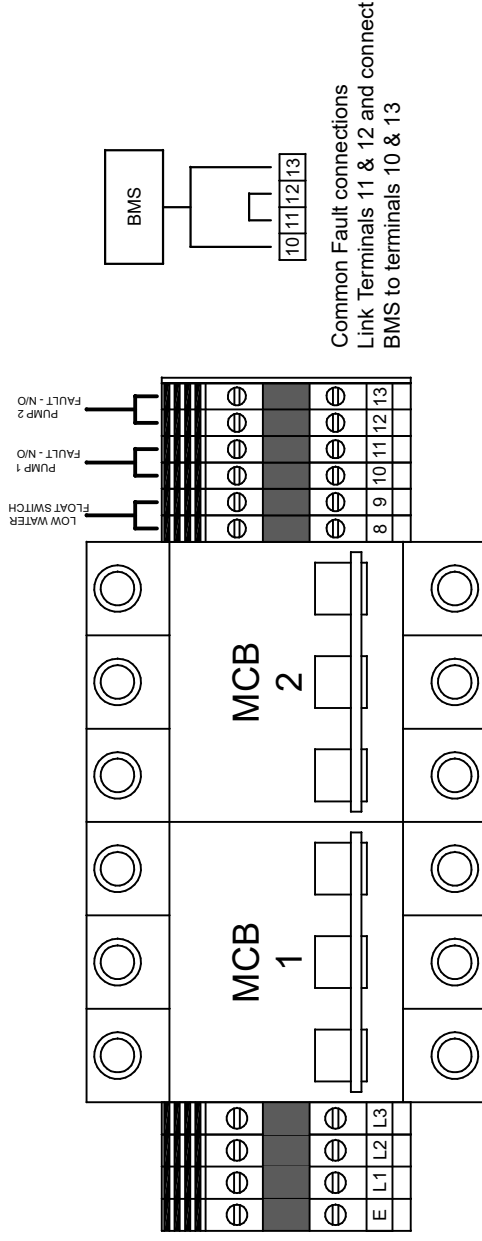

Common Fault connections  
Link Terminals 11 & 12 and connect  
BMS to terminals 10 & 13

DRAWING NO.

**FB.PRIME.2V.3-WD.R2**

TITLE

**Flowboost PRIME 2V.3 Wiring Diagram**

TEL

0333 200 1756

Notes:

ALL DIMENSIONS ± 1mm UNLESS STATED OTHERWISE



DRAWN BY  
**P. EARL**

DATE  
**18/04/2023**

EMAIL

info@flowtech.org.uk

WEBSITE

www.flowtech.org.uk

Scale  
**1:1**

ALL DIMENSIONS IN MM - DNS

**A4**



Please note that the drawing must be read in conjunction with the installation & operating guidelines



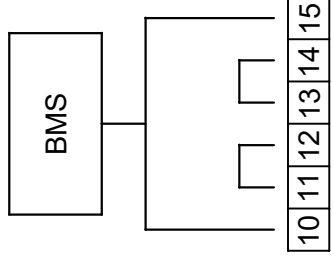
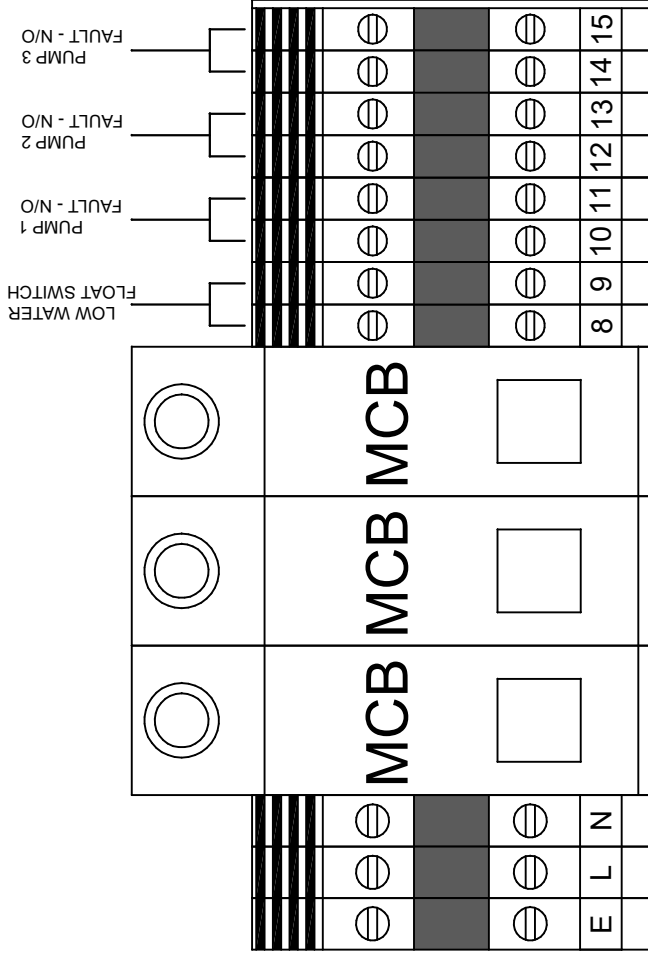

Common Fault connections  
 Link Terminals 11 & 12, 13 & 14 and  
 connect BMS to terminals 10 & 15

DRAWING NO.

**FB.PRIME.3V.1-WD.R2**

TITLE

**Flowboost PRIME 3V.1 Wiring Diagram**

TEL

0333 200 1756

Notes:

ALL DIMENSIONS ± 1mm UNLESS STATED OTHERWISE

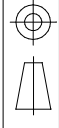

DRAWN BY  
**P. EARL**

DATE  
**18/04/2023**

Scale  
**1:1**

**A4**

ALL DIMENSIONS IN MM - DNS

EMAIL

info@flowtech.org.uk

WEBSITE

www.flowtech.org.uk



Please note that the drawing must be read in conjunction with the installation & operating guidelines

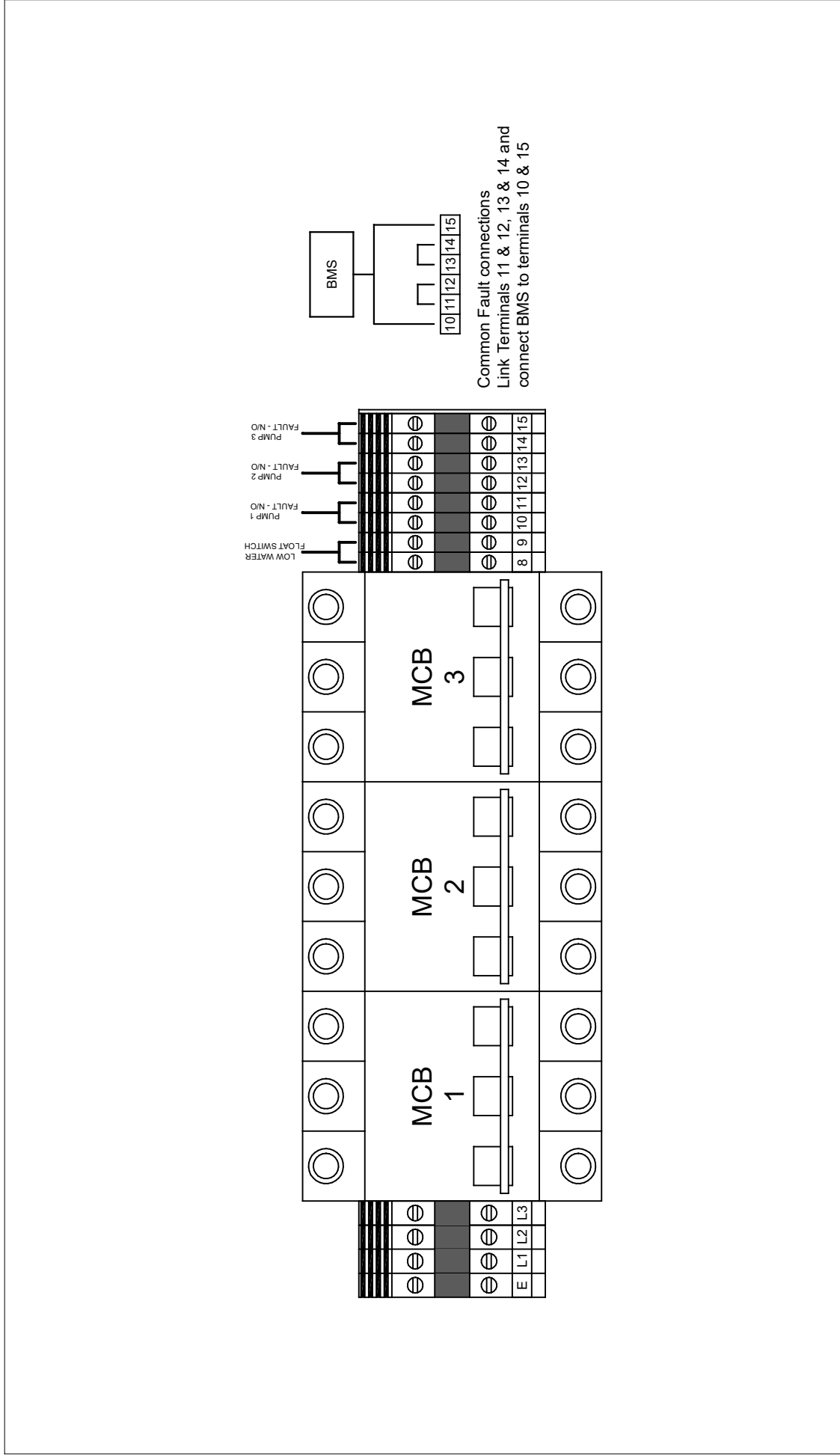

DRAWING NO. <b>FB.PRIME.3V.3-WD.R2</b>	TITLE <b>Flowboost PRIME 3V.3 Wiring Diagram</b>	TEL 0333 200 1756	Notes:
	ALL DIMENSIONS ± 1mm UNLESS STATED OTHERWISE Scale <b>1:1</b>	DRAWN BY <b>P. EARL</b>	
	DATE <b>18/04/2023</b>	WEBSITE www.flowtech.org.uk	
	<b>A4</b>		



Please note that the drawing must be read in conjunction with the installation & operating guidelines



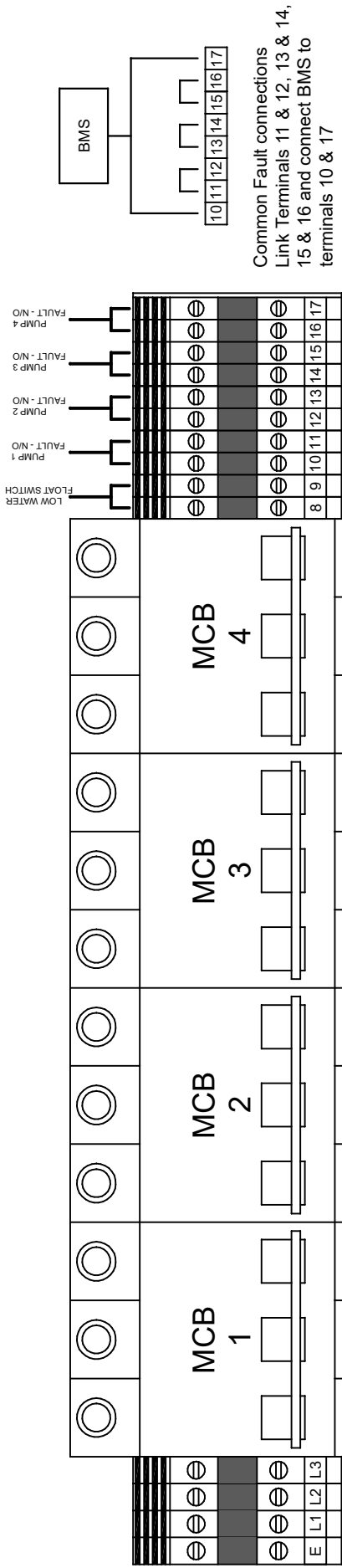

Common Fault connections  
Link Terminals 11 & 12, 13 & 14,  
15 & 16 and connect BMS to  
terminals 10 & 17

DRAWING NO.

**FB.PRIME.4V.3-WD.R2**

TITLE

**Flowboost PRIME 4V.3 Wiring Diagram**

TEL

0333 200 1756

Notes:

ALL DIMENSIONS ± 1mm UNLESS STATED OTHERWISE

Scale

1:1



**A4**

DRAWN BY  
**P. EARL**

DATE  
**18/04/2023**

ALL DIMENSIONS IN MM - DNS

EMAIL

info@flowtech.org.uk

WEBSITE

www.flowtech.org.uk



Please note that the drawing must be read in conjunction with the installation & operating guidelines



Certificate number: 2402730 (1)

Issued 12/02/2024

Expires 12/02/2029

## Kiwa Regulation 4 (KUKreg4) Certification

Evaluation Guideline – Kiwa UK – EG004 – Regulation 4(1)(a)

Model number(s) – see Appendix

### Flowtech Water Solutions Ltd.

Kiwa Watertec declares that legitimate confidence exists in the products specified in this certificate and supplied by the above organisation be relied upon to comply with the Kiwa Evaluation Guideline referred above.

Which verifies the requirements of:

**Regulation 4(1)a of the Water Supply (Water Fittings) Regulations 1999 England & Wales: 2009 Northern Ireland and 2014 Byelaws Scotland.**

This certificate has been issued in accordance with the Kiwa regulations for product certification.

Signed on behalf of Kiwa Watertec

David Jay, Business Unit Manager – Authorised Signatory  
Kiwa Watertec

Publication of this certificate is allowed.

Products are intended to be used in the UK only. For other countries, other (National) requirements will apply.

See <https://www.kiwa.com/gb/en/about-kiwa/water-products/> or the QR code below to ensure that the certificate is still valid.

# CERTIFICATE

Kiwa Watertec  
(A Trading Division of Kiwa Ltd)  
26A Rassau Industrial Estate  
Ebbw Vale  
Gwent  
NP23 5SD  
United Kingdom  
T +44 (0)1495 308185  
[uk.water@kiwa.com](mailto:uk.water@kiwa.com)  
[www.kiwa.co.uk](http://www.kiwa.co.uk)

**Certificate Issued to:**  
Flowtech Water Solutions Ltd  
Unit 1 Lockflight Buildings  
Wheatlea Road  
Wheatlea Industrial Estate  
Wigan  
Greater Manchester  
WN3 6XP  
United Kingdom



**KUKreg4**

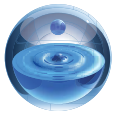

**flowtech**<sup>®</sup>  
WATER SOLUTIONS

# flowzone<sup>®</sup>

MEMBERS AREA

This section of the **flowtech**<sup>®</sup> website holds information exclusively for members. Members will need to log in to gain access to these pages.

Our member's will be granted exclusive access to our technical resource library. Within this resource is a wide range of product information including data sheets, technical drawings, O&M Manuals and training videos



# flowcare<sup>®</sup>

AFTER SALES SERVICE

At **flowtech**<sup>®</sup> we operate a network of Service Engineers located throughout the UK who are supported by our offices located in and Greater Manchester. The distribution of engineers means that in the majority of cases we are less than 4 hours away from attending a customer call out.

We place great emphasis on providing technical back up to support our Service Engineers in resolving some difficult operational and technical issues. We pride ourselves on completing a project on time, within budget and never leaving a problem unresolved, or a customer waiting. This quality of service has made us the first choice for our customers.

FOR FURTHER INFORMATION OR ASSISTANCE

## contact us

Flowtech Water Solutions are experts in water services and water booster sets. We have continuously supplied a wide range of standard and custom products since being founded in 1996.

### MANUFACTURE & SUPPLY

TELEPHONE : 0333 200 1756

EMAIL: [info@flowtech.org.uk](mailto:info@flowtech.org.uk)

### SERVICE & MAINTENANCE

TELEPHONE : 0333 200 1813

EMAIL: [service@flowtech.org.uk](mailto:service@flowtech.org.uk)

WEBSITE: [www.flowtech.org.uk](http://www.flowtech.org.uk)

ADDRESS : Unit 1 Lock Flight Buildings, Wheatlea Industrial Estate,  
Wigan, Greater Manchester WN3 6XP United Kingdom

